

Engine Generator Circuit Breakers



Engine Generator Circuit Breakers

Product Description

Eaton's engine generator molded case circuit breakers are designed specifically for application on diesel engine powered standby generators where high interrupting circuit breakers are not required. The JG through NG breakers are equipped with a special trip unit, that includes standard thermal (overload) protection and special low magnetic pickup range (FG includes a fixed thermal-magnetic pickup). The standard thermal trip unit provides overload protection for conductors per the National Electrical Code®. The low magnetic pickup range is approximately two to five times the continuous rating and provides closer low-level short-circuit protection when applied on generators that have very low short-circuit capacity. This combination allows the user to customize the breaker to the generator output.

Application Description

Engine generator circuit breakers are suitable for reverse feed application.

Contents

Description

	<i>Page</i>
Engine Generator Circuit Breakers	
Catalog Number Selection	V4-T2-438
Product Selection	V4-T2-439
Accessories Selection Guide and Ordering Information	V4-T2-441
Options and Accessories	V4-T2-441
Technical Data and Specifications	V4-T2-442
Dimensions and Weights	V4-T2-442
Direct Current Circuit Breakers	V4-T2-443
PVGard Solar Circuit Breakers—600 Vdc Per-Pole and 1000 Vdc Poles-in-Series	V4-T2-457
E ² Mining Service Circuit Breakers	V4-T2-470

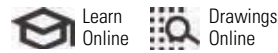

Standards and Certifications

Engine generator molded case circuit breakers are designed to conform with the following standards:

- Underwriters Laboratories Standard UL 489, Molded Case Circuit Breakers and Circuit Breaker Enclosures File E7819
- Canadian Standards Association Standard C22.2 No. 5, Service Entrance and Branch Circuit Breakers
- International Electrotechnical Commission Recommendations IEC 947-2, Circuit Breakers



Conformance with these standards satisfies most local and international codes, assuming user acceptability and simplified application.

2.5

Molded Case Circuit Breakers

Specialty Breakers

2

Catalog Number Selection

This information is presented only as an aid to understanding catalog numbers. It is not to be used to build catalog numbers for circuit breakers.

- FG breakers include both line and load side terminals

- JG, KG, LG and NG breakers with **W** catalog number suffix do not include any terminals
- JG, KG, LG and NG breakers without **W** catalog number suffix include both line and load terminals
- Contact Eaton for additional ratings and internal/external accessories
- Reverse feed

Circuit Breakers FG, JG, KG, LG and NG

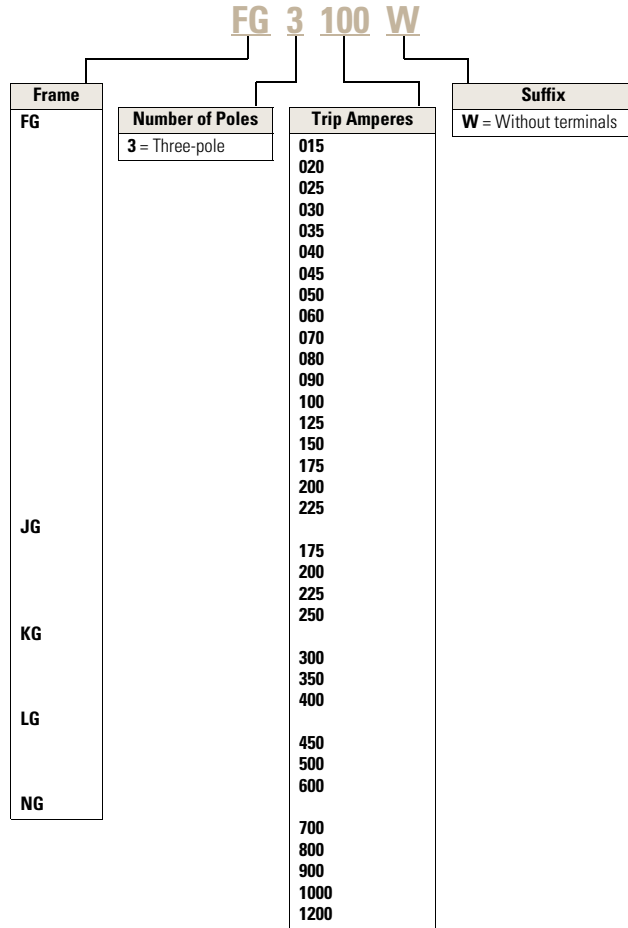

Product Selection

The following table lists FG through NG engine generator breakers with the maximum generator kVA and kW rating. Engine generator breakers are applied at 115% of the

generator full load current rating (FLA). The maximum kW rating is based on three-phase generators at 80% power factor.

Thermal-Magnetic

Magnetic Pickup Range	Maximum Generator Rating 60 Hz				600 Vac		Engine Generator Breaker ^③
	240 Vac kVA ^①	kW ^②	480 Vac kVA ^①	kW ^②	kVA ^①	kW ^②	Catalog Number
Fixed	5	4	11	9	14	11	FG3015 ^④
Fixed	7	6	14	12	18	14	FG3020 ^④
Fixed	9	7	18	14	23	18	FG3025 ^④
Fixed	11	9	22	17	27	22	FG3030 ^④
Fixed	13	10	25	20	32	25	FG3035 ^④
Fixed	14	12	29	23	36	29	FG3040 ^④
Fixed	16	13	32	26	41	32	FG3045 ^④
Fixed	18	14	36	29	45	36	FG3050 ^④
Fixed	22	17	43	35	54	43	FG3060 ^④
Fixed	25	20	51	40	63	51	FG3070 ^④
Fixed	29	23	58	46	72	58	FG3080 ^④
Fixed	32	26	65	52	81	65	FG3090 ^④
Fixed	36	29	72	58	90	72	FG3100 ^④
Fixed	40	32	79	64	99	79	FG3110 ^④
Fixed	45	36	90	72	113	90	FG3125 ^④
Fixed	54	43	108	87	135	108	FG3150 ^④
Fixed	63	51	126	101	158	126	FG3175 ^④
Fixed	72	58	144	116	181	144	FG3200 ^④
Fixed	81	65	162	130	203	162	FG3225 ^④
350–700	63	51	126	101	158	126	JG3175W ^⑤
350–700	63	51	126	101	158	126	JG3175 ^④
350–700	72	58	144	116	181	144	JG3200W ^⑤
350–700	72	58	144	116	181	144	JG3200 ^④
350–700	81	65	162	130	203	162	JG3225W ^⑤
350–700	81	65	162	130	203	162	JG3225 ^④
350–700	90	72	181	144	226	181	JG3250W ^⑤
350–700	90	72	181	144	226	181	JG3250 ^④
500–1000	108	87	217	173	271	217	KG3300W ^⑤
500–1000	108	87	217	173	271	217	KG3300 ^④
500–1000	126	101	253	202	316	253	KG3350W ^⑤
500–1000	126	101	253	202	316	253	KG3350 ^④
1000–2000	144	116	289	231	361	289	KG3400 ^④

Notes

- ① Breaker continuous current is based on 115% of the generator full load ampere rating.
- ② Based on three-phase generators at 80% power factor.
- ③ FG, JG, KG include thermal-magnetic trip units, LG and NG include electronic trip units.
- ④ Breaker includes line and load terminals.
- ⑤ Without terminals.

The following catalog numbers have center tap studs for dual voltage applications: JG3070CT, JG3100CT, JG3125CT, KG3175CT, LG3300CTW.

Electronic

2

Magnetic Pickup Range	Maximum Generator Rating 60 Hz		480 Vac		600 Vac		Engine Generator Breaker ^③
	240 Vac kVA ^①	kW ^②	kVA ^①	kW ^②	kVA ^①	kW ^②	Catalog Number
500–2500	162	130	325	260	406	325	LG3450 ^④
500–2500	181	144	361	289	451	361	LG3500 ^④
500–2500	217	173	433	347	542	433	LG3600 ^④
500–2500	253	202	505	404	632	505	NG3700 ^④
500–2500	289	231	578	462	722	578	NG3800 ^④
1250–5000	325	260	650	520	812	650	NG3900 ^④
1250–5000	361	289	722	578	903	722	NG31000 ^④
1250–5000	433	347	867	693	1083	867	NG31200 ^④

Notes

- ① Breaker continuous current is based on 115% of the generator full load ampere rating.
- ② Based on three-phase generators at 80% power factor.
- ③ FG, JG, KG include thermal-magnetic trip units, LG and NG include electronic trip units.
- ④ Breaker includes line and load terminals.

The following catalog numbers have center tap studs for dual voltage applications: JG3070CT, JG3100CT, JG3125CT, KG3175CT, LG3300CTW.

Accessories Selection Guide and Ordering Information

Enclosures

Type 1 General Purpose

- Surface or flush mounting
- 15–1200 ampere range
- 600 Vac, 500 Vdc

Type 1 enclosed breakers are designed for use in commercial buildings, apartment buildings and other areas where a general purpose enclosure is applicable. The breaker is front operable and is capable of being padlocked in either the ON or OFF position. Ratings through 1200 amperes are listed with Underwriters Laboratories as approved for service entrance application. Both surface and flush mounted enclosures are available.

Type 3R Rainproof Surface Mounting

- Interchangeable hubs (through 400 amperes)
- 15–1200 ampere range
- 600 Vac, 500 Vdc

This general purpose outdoor service center employs a circuit breaker inside a weatherproof sheet steel breaker enclosure to serve

as a main disconnect and protective device for feeder circuits. Ratings through 1200 amperes are listed by Underwriters Laboratories as suitable for service entrance application.

Type 12 Dustproof Surface Mounting

- No knockouts or other openings
- 15–1200 ampere range
- 600 Vac, 500 Vdc

The Type 12 enclosure is designed in line with specifications for special industry applications where unusually severe conditions involving oil, coolant, dust and other foreign materials exist in the operating atmosphere. The handle padlocks in the OFF position and the cover is interlocked with the handle mechanism to prevent opening the cover with the circuit breaker in the ON position. Ratings through 1200 amperes are listed by Underwriters Laboratories as suitable for service entrance application.

Enclosure Selection Data

Breaker Frame Amperes	Enclosure Type Class	Catalog Number
FG 15–225	Type 1	SFDN225
	Type 3R	RFDN225
	Type 12	JFDN225
JG 175–250	Type 1	SJDN250
	Type 3R	RJDN250
	Type 12	JJDN250
KG 300–400	Type 1	SKDN400
	Type 3R	RKDN400
	Type 12	JKDN400
LG 450–600	Type 1	SLDN600
	Type 3R	RLDN600
	Type 12	JLDN600
NG 700–1200	Type 1	SNDN1200
	Type 3R	RNDN1200
	Type 12	JNDN1200

Options and Accessories

Standard Terminals

Breaker Frame	Max. Amp Rating	AWG Wire Range	Metric Wire Range mm ²	Catalog Number
FG	100	14–1/0	2.5–50	3T100FB ①
FG	150	4–4/0	25–95	3TA225FD ①
JG	250	4–350 kcmil	25–185	TA250KB
KG	350	250–500 kcmil	120–240	TA350K
KG	400	3/0–250 kcmil (2)	95–120	3TA400K ①
LG	600	250–500 kcmil (2)	120–240	3TA603LDK
NG	700	1–500 kcmil (2)	50–300	TA700NB1
NG	1000	3/0–400 kcmil (3)	95–185	TA1000NB1
NG	1200	4/0–500 kcmil (4)	120–300	TA1200NB1

Neutral Kits, Insulated and Groundable

Max. Enclosure Rating (Amperes)	Main Lug Number Size Cu/Al	Ground Lug Size Cu/Al	Catalog Number
100	(1) 14–1/0	(1) 14–1/0	INK100
250	(1) 6–350 kcmil	(1) 4–300 kcmil	INK250
400	(1) 4–750 kcmil or (2) 1/0–250 kcmil	(1) 4–300 kcmil	INK400
600	(2) 250–500 kcmil	(1) 4–300 kcmil	INK600
1200	(3) 1/0 to 750 kcmil or (4) 1/0 to 750 kcmil	(1) 6–250 kcmil	INK1200

Internal Accessories

Auxiliary Switch ②

Breaker Frame	Factory Mounted	1A-1B		2A-2B	
		Field Kit Catalog Number	Factory Mounted	Field Kit Catalog Number	Factory Mounted
FG ③	A06	A1X1PK	A13	A2X1RPK	A13
JG	A06	A1X2PK	A13	A2X2PK	A13
KG	A06	A1X3PK	A13	A2X3PK	A13
LG	A06	A1X4PK	A13	A2X4PK	A13
NG	A06	A1X5PK	A13	A2X5PK	A13

Shunt Trip ②

Breaker Frame	Rating	Factory Mounted	Field Kit Catalog Number
FG ③	12–24 Vdc	S02	SNT1LP03K
JG	12–24 Vdc	S42	SNT2P04K
KG	12–24 Vdc	S42	SNT3P04K
LG	12–24 Vdc	S02	SNT4LP03K
NG	12–24 Vdc	S02	SNT5LP03K

Notes

- ① Package of three terminals.
- ② Other accessories are available. Same as standard frame breakers.
- ③ Field installation on the FG Frame is not UL listed.

2.5

Molded Case Circuit Breakers

Specialty Breakers

2

Technical Data and Specifications

UL 489 Interrupting Capacity Ratings

Volts AC (50/60 Hz)	Interrupting Capacity (Symmetrical Amperes)
240	18,000
480	14,000
600	10,000

IEC 947-2 Interrupting Capacity Ratings

Volts AC (50/60 Hz)	Interrupting Capacity (Symmetrical Amperes)
220, 240	18,000/9,000
380, 415	14,000/7,000
660, 690	18,000/9,000 14,000/7,000 10,000/5,000

Dimensions and Weights

Approximate Dimensions in Inches (mm)

Enclosure Selection Data

Breaker Frame Amperes	Enclosure Type Class	A	B	C	D	E	Approx. Weight Lbs (kg)	Conduit Sizes, Inches	Catalog Number
FG 15–225	Type 1	23.25 (590.6)	8.41 (213.6)	6.28 (159.5)	18.75 (476.3)	1.20 (30.5)	15 (7)	0.25, 0.50, 0.75, 1, 1.25, 1.50, 2, 2.50	SFDN225
	Type 3R	25.66 (651.8)	8.84 (224.7)	9.31 (236.5)	24.28 (616.7)	1.70 (43.2)	19 (9)	0.25, 0.50, 0.75, 1, 1.25, 1.50, 2, 2.50	RFDN225
	Type 12	25.66 (651.8)	8.84 (224.7)	9.31 (236.5)	24.28 (616.7)	1.70 (43.2)	18 (8)	—	JFDN225
JG 175–250	Type 1	34.70 (881.4)	10.92 (277.4)	7.20 (182.9)	30.00 (762.0)	1.88 (47.8)	31 (14)	0.25, 0.50, 2, 2.50, 3	SJDN250
	Type 3R	37.50 (952.5)	11.56 (293.6)	10.22 (259.6)	35.77 (908.6)	1.94 (49.3)	40 (18)	0.25, 0.50, 2, 2.50, 3	RJDN250
	Type 12	37.53 (953.3)	11.56 (293.6)	10.22 (259.6)	35.77 (908.6)	1.94 (49.3)	37 (17)	—	JJDN250
KG 300–400	Type 1	38.81 (985.8)	11.06 (280.9)	10.94 (277.9)	34.00 (863.6)	2.28 (57.9)	53 (24)	0.25, 0.50, 0.75, 1.50, 2, 2.50, 3, 3.50	SKDN400
	Type 3R	41.69 (1058.9)	11.75 (298.5)	14.06 (357.1)	39.90 (1013.5)	1.97 (50.0)	60 (27)	0.25, 0.50, 0.75, 2.50, 3, 3.50	RKDN400
	Type 12	41.69 (1058.9)	11.75 (298.5)	14.06 (357.1)	39.90 (1013.5)	1.97 (50.0)	53 (24)	—	JKDN400
LG 450–600	Type 1	45.88 (1165.4)	14.31 (363.5)	12.38 (314.5)	46.56 (1182.6)	1.91 (48.5)	81 (37)	0.25, 0.50, 0.75, 3, 3.50, 4	SLDN600
	Type 3R	48.31 (1227.1)	14.91 (378.7)	15.50 (393.7)	46.56 (1182.6)	1.92 (48.8)	84 (38)	0.25, 0.50, 0.75, 3, 3.50, 4	RLDN600
	Type 12	48.31 (1227.1)	14.91 (378.7)	15.50 (393.7)	46.56 (1182.6)	1.92 (48.8)	81 (37)	—	JLDN600
NG 700–1200	Type 1	61.22 (1555.0)	21.44 (544.6)	15.41 (391.4)	61.84 (1570.7)	1.97 (50.0)	178 (81)	—	SNDN1200
	Type 3R	63.59 (1615.2)	22.00 (558.8)	17.63 (447.8)	61.84 (1570.7)	1.97 (50.0)	175 (79)	—	RNDN1200
	Type 12	63.59 (1615.2)	22.00 (558.8)	17.63 (447.8)	61.84 (1570.7)	1.97 (50.0)	170 (77)	—	JNDN1200

Type 1 Surface Mounted

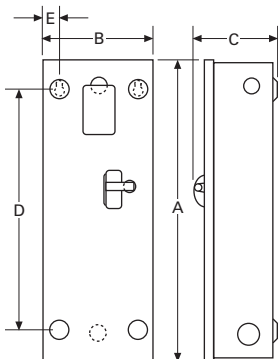

Type 3R Rainproof

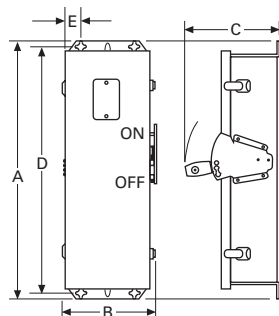

Type 12, 12K Dustproof

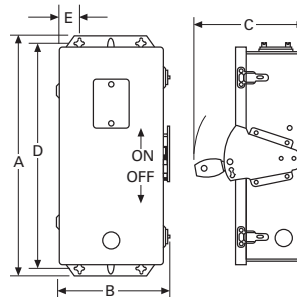

Direct Current Circuit Breakers



Direct Current Circuit Breakers

Product Description

DC (direct current) systems and applications are becoming commonplace as alternative energy sources have expanded and the number of DC devices and data centers using DC power has swelled.

Eaton offers molded case circuit breakers and switches to meet circuit protection and switching requirements for a host of different DC end user requirements. Applications include UPS battery supply circuits, solar systems and electric vehicle charging, as well as commercial and industrial distribution.

Current ratings are available from 15 to 3000 A, with a full scale of voltage and interrupting ratings to address needs ranging from standard to the highest performance. Optional internal accessories provide remote tripping and indication of breaker status.

The DC breaker family is UL 489 listed and exceeds the requirements in UL 489 Supplement SC for UPS applications. Eaton breakers may be applied in both ungrounded and select grounded applications, with poles connected in series to operate at the maximum voltages shown on **Page V4-T2-444**. To use DC circuit breakers on 600 V grounded systems, three poles in series must be connected on the ungrounded leg.

Contents

Description

	<i>Page</i>
Engine Generator Circuit Breakers	V4-T2-437
Direct Current Circuit Breakers	
Catalog Number Selection	V4-T2-445
Product Selection	V4-T2-446
Accessories	V4-T2-453
Wiring Diagrams	V4-T2-455
Dimensions	V4-T2-456
PVGard Solar Circuit Breakers—600 Vdc Per-Pole and 1000 Vdc Poles-in-Series	V4-T2-457
E ² Mining Service Circuit Breakers	V4-T2-470

All DC breakers use the same internal and external accessories as their corresponding Series C and Series G AC frame equivalents, except for the NBDC breaker, which uses the same internal and external accessories as the standard NB frame.

The HFDDC through HMDLDC and EG to RG DC breakers use the same internal and external accessories as their corresponding Series C and Series G AC Frame equivalents. NBDC uses the same internal and external accessories as standard NB breakers.

Many of the Eaton AC molded case circuit breakers carry 250 Vdc ratings for ungrounded systems. Refer to **Pages V4-T2-113** and **V4-T2-222** for these interrupting tables.

Quick Reference Direct Current Circuit Breakers

UL 489 Interrupting Capacity Ratings

Interrupting Capacity (kA)
Volts DC ^①

Circuit Breaker Type	Maximum Amperes	Interrupting Capacity (kA)								
		125 Volts DC ^①			500 Volts DC ^①			750 Volts DC ^②		
		125	Poles in Series	250 ^②	Poles in Series	500	600	Poles in Series	750 ^②	Poles in Series
EGEDC	100	10	1	35	2	35	—	3	—	—
EGSDC	100	35	1	42	2	50	—	3	—	—
EGHDC	100	42	1	50	2	65	—	3	—	—
HFDDC	225	42	1	50	2	—	42	3	42	4
JGEDC	250	35	1	35	2	—	35	3	—	—
JGSDC	250	42	1	42	2	—	50	3	—	—
JGHDC	250	50	1	50	2	—	65	3	—	—
HJDDC	250	42	1	50	2	—	42	3	—	—
HKDDC	400	42	1	50	2	—	42	3	—	—
LGEDC	600	22	1	22	2	—	35	3	—	—
LGSDC	600	22	1	22	2	—	50	3	—	—
LGHDC	600	50	1	50	2	—	65	3	—	—
HLDDC	600	42	1	50	2	—	35	3	—	—
HLDDC ^③	1200	42	1	50	2	—	—	—	—	—
HMDLDC	800	42	1	50	2	—	35	3	—	—
NBDC	1200	42	1	50	2	—	50	3	—	—
RGHDC	3000	42	1	50	2	—	65	3	—	—

IEC 60947-2 Interrupting Capacity Ratings

Circuit Breaker Type	Maximum Amperes	125 Volts DC		Poles in Series	250 Volts DC		Poles in Series	600 Volts DC		Poles in Series
		Icu	Ics		Icu	Ics		Icu	Ics	
EGEDC	100	10	10	1	10	10	2	—	—	—
EGSDC	100	35	35	1	35	35	2	—	—	—
EGHDC	100	42	42	1	42	42	2	—	—	—
JGEDC	250	22	22	1	22	22	2	—	—	—
JGSDC	250	22	22	1	22	22	2	—	—	—
JGHDC	250	42	42	1	42	42	2	—	—	—
HJDDC	250	—	—	—	—	—	—	20	10	3
LGEDC	600	22	22	1	22	22	2	—	—	—
LGSDC	600	22	22	1	22	22	2	—	—	—
LGHDC	600	42	42	1	42	42	2	—	—	—
HLDDC	600	—	—	—	—	—	—	20	10	3
HMDLDC	800	—	—	—	—	—	—	20	10	3

Notes

^① DC ratings apply to substantially non-inductive circuits. Time constants per UL 489.

^② EGEDC through HMDLDC have been tested up to 300 Vdc to allow for battery charging voltages. 750 Vdc is common in transportation applications. HFDDC, four-pole 750 Vdc is available up to 150 A maximum. 300 Vdc and 750 Vdc are not UL 489 listed voltage ratings.

^③ Four-pole frame with two-poles connected in parallel.

See Page V4-T2-455 for series connection diagrams. Use NEC rated cable to connect/short poles in series as shown.

Catalog Number Selection

This information is presented only as an aid to understanding catalog numbers. It is not to be used to build catalog numbers for circuit breakers or trip units.

DC Circuit Breaker

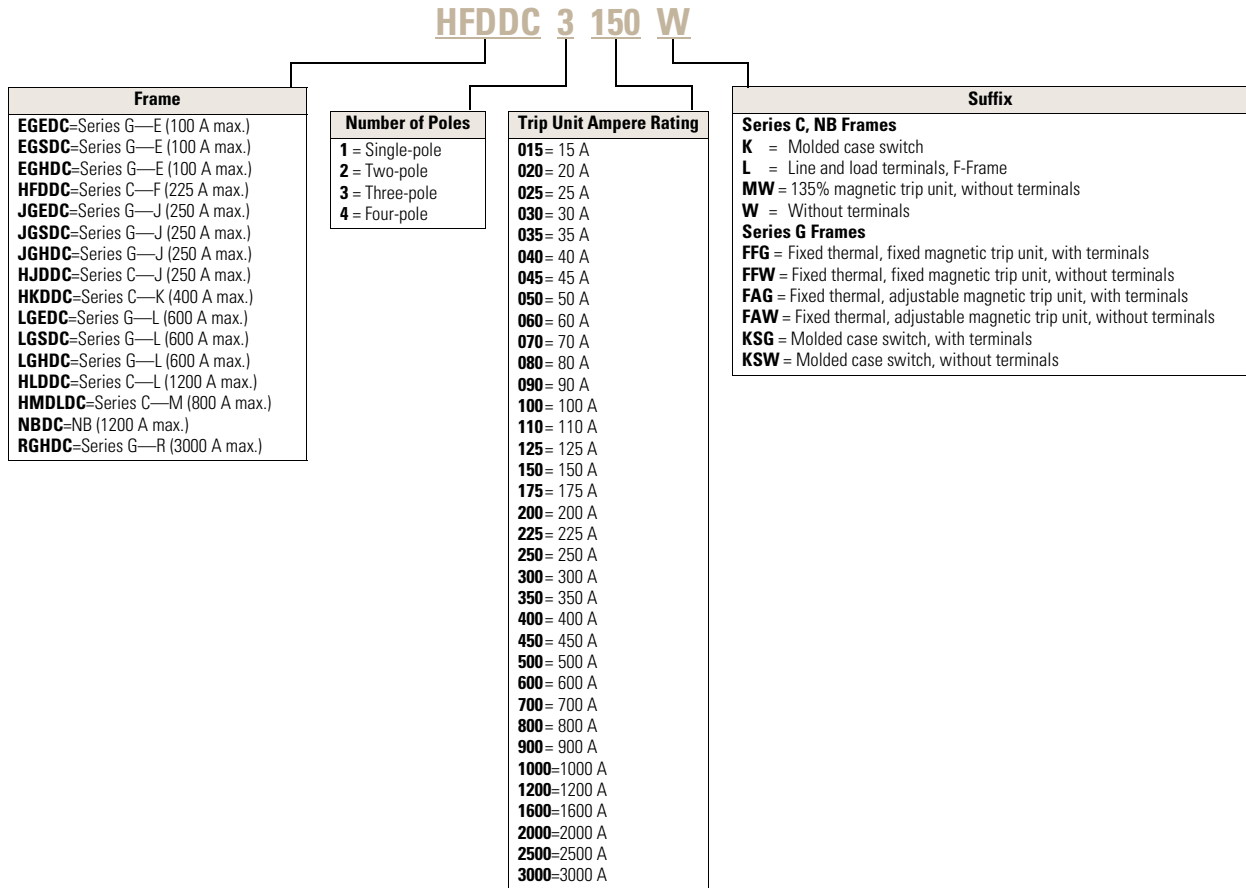

Product Selection

2

**Type EGEDC DC Circuit Breakers—
Three-Pole High Interrupting Capacity 35 kAIC at 500 Vdc**

Maximum Continuous Ampere Rating at 40 °C	Complete Circuit Breaker with Terminals Catalog Number	Complete Circuit Breaker without Terminals Catalog Number
25	EGEDC3025FFG	EGEDC3025FFW
30	EGEDC3030FFG	EGEDC3030FFW
35	EGEDC3035FFG	EGEDC3035FFW
40	EGEDC3040FFG	EGEDC3040FFW
45	EGEDC3045FFG	EGEDC3045FFW
50	EGEDC3050FFG	EGEDC3050FFW
60	EGEDC3060FFG	EGEDC3060FFW
70	EGEDC3070FFG	EGEDC3070FFW
80	EGEDC3080FFG	EGEDC3080FFW
90	EGEDC3090FFG	EGEDC3090FFW
100	EGEDC3100FFG	EGEDC3100FFW

**Type EGSDC DC Circuit Breakers—
Three-Pole High Interrupting Capacity 50 kAIC at 500 Vdc**

Maximum Continuous Ampere Rating at 40 °C	Complete Circuit Breaker with Terminals Catalog Number	Complete Circuit Breaker without Terminals Catalog Number
25	EGSDC3025FFG	EGSDC3025FFW
30	EGSDC3030FFG	EGSDC3030FFW
35	EGSDC3035FFG	EGSDC3035FFW
40	EGSDC3040FFG	EGSDC3040FFW
45	EGSDC3045FFG	EGSDC3045FFW
50	EGSDC3050FFG	EGSDC3050FFW
60	EGSDC3060FFG	EGSDC3060FFW
70	EGSDC3070FFG	EGSDC3070FFW
80	EGSDC3080FFG	EGSDC3080FFW
90	EGSDC3090FFG	EGSDC3090FFW
100	EGSDC3100FFG	EGSDC3100FFW

**Type EGHDC DC Circuit Breakers—
Three-Pole High Interrupting Capacity 65 kAIC at 500 Vdc**

Maximum Continuous Ampere Rating at 40 °C	Complete Circuit Breaker with Terminals Catalog Number	Complete Circuit Breaker without Terminals Catalog Number
25	EGHDC3025FFG	EGHDC3025FFW
30	EGHDC3030FFG	EGHDC3030FFW
35	EGHDC3035FFG	EGHDC3035FFW
40	EGHDC3040FFG	EGHDC3040FFW
45	EGHDC3045FFG	EGHDC3045FFW
50	EGHDC3050FFG	EGHDC3050FFW
60	EGHDC3060FFG	EGHDC3060FFW
70	EGHDC3070FFG	EGHDC3070FFW
80	EGHDC3080FFG	EGHDC3080FFW
90	EGHDC3090FFG	EGHDC3090FFW
100	EGHDC3100FFG	EGHDC3100FFW

HFDDC

**Type HFDDC DC Circuit Breakers—
Three-Pole High Interrupting Capacity 42 kAIC at 600 Vdc**

Maximum Continuous Ampere Rating at 40 °C	Complete Circuit Breaker with Line and Load Terminals ^①			
	Single-Pole Catalog Number	Two-Pole Catalog Number	Three-Pole Catalog Number	Four-Pole Catalog Number
15	HFDDC1015L	HFDDC2015L	HFDDC3015L	HFDDC4015L
20	HFDDC1020L	HFDDC2020L	HFDDC3020L	HFDDC4020L
25	HFDDC1025L	HFDDC2025L	HFDDC3025L	HFDDC4025L
30	HFDDC1030L	HFDDC2030L	HFDDC3030L	HFDDC4030L
35	HFDDC1035L	HFDDC2035L	HFDDC3035L	HFDDC4035L
40	HFDDC1040L	HFDDC2040L	HFDDC3040L	HFDDC4040L
45	HFDDC1045L	HFDDC2045L	HFDDC3045L	HFDDC4045L
50	HFDDC1050L	HFDDC2050L	HFDDC3050L	HFDDC4050L
60	HFDDC1060L	HFDDC2060L	HFDDC3060L	HFDDC4060L
70	HFDDC1070L	HFDDC2070L	HFDDC3070L	HFDDC4070L
80	HFDDC1080L	HFDDC2080L	HFDDC3080L	HFDDC4080L
90	HFDDC1090L	HFDDC2090L	HFDDC3090L	HFDDC4090L
100	HFDDC1100L	HFDDC2100L	HFDDC3100L	HFDDC4100L
110	HFDDC1110L	HFDDC2110L	HFDDC3110L	HFDDC4110L
125	HFDDC1125L	HFDDC2125L	HFDDC3125L	HFDDC4125L
150	HFDDC1150L	HFDDC2150L	HFDDC3150L	HFDDC4150L
175	—	HFDDC2175L	HFDDC3175L	—
200	—	HFDDC2200L	HFDDC3200L	—
225	—	HFDDC2225L	HFDDC3225L	—

**Type JGEDC DC Circuit Breakers—
Three-Pole High Interrupting Capacity 35 kAIC at 600 Vdc**

Maximum Continuous Ampere Rating at 40 °C	Complete Breaker Catalog Number	Circuit Breaker Frame Only ^② Catalog Number	Thermal-Magnetic Trip Unit Catalog Number	Standard Terminals Catalog Number
70	JGEDC3070FAG	JGEDC3250NN	JT3070FA	T250FJ
90	JGEDC3090FAG	JGEDC3250NN	JT3090FA	T250FJ
100	JGEDC3100FAG	JGEDC3250NN	JT3100FA	T250FJ
125	JGEDC3125FAG	JGEDC3250NN	JT3125FA	T250FJ
150	JGEDC3150FAG	JGEDC3250NN	JT3150FA	T250FJ
175	JGEDC3175FAG	JGEDC3250NN	JT3175FA	T250FJ
200	JGEDC3200FAG	JGEDC3250NN	JT3200FA	T250FJ
225	JGEDC3225FAG	JGEDC3250NN	JT3225FA	T250FJ
250	JGEDC3250FAG	JGEDC3250NN	JT3250FA	T250FJ

Notes

① For breaker without terminals, replace "L" with "W" at end of catalog number.

② For complete breaker, order individual frame, trip unit and terminals for field installation.

Type JGSDC DC Circuit Breakers— Three-Pole High Interrupting Capacity 50 kAIC at 600 Vdc

Maximum Continuous Ampere Rating at 40 °C	Complete Breaker Catalog Number	Circuit Breaker Frame Only ^① Catalog Number	Thermal-Magnetic Trip Unit Catalog Number	Standard Terminals Catalog Number
70	JGSDC3070FAG	JGSDC3250NN	JT3070FA	T250FJ
90	JGSDC3090FAG	JGSDC3250NN	JT3090FA	T250FJ
100	JGSDC3100FAG	JGSDC3250NN	JT3100FA	T250FJ
125	JGSDC3125FAG	JGSDC3250NN	JT3125FA	T250FJ
150	JGSDC3150FAG	JGSDC3250NN	JT3150FA	T250FJ
175	JGSDC3175FAG	JGSDC3250NN	JT3175FA	T250FJ
200	JGSDC3200FAG	JGSDC3250NN	JT3200FA	T250FJ
225	JGSDC3225FAG	JGSDC3250NN	JT3225FA	T250FJ
250	JGSDC3250FAG	JGSDC3250NN	JT3250FA	T250FJ

JGHDC3250NN



Type JGHDC DC Circuit Breakers— Three-Pole High Interrupting Capacity 65 kAIC at 600 Vdc

Maximum Continuous Ampere Rating at 40 °C	Complete Breaker Catalog Number	Circuit Breaker Frame Only ^① Catalog Number	Thermal-Magnetic Trip Unit Catalog Number	Standard Terminals Catalog Number
70	JGHDC3070FAG	JGHDC3250NN	JT3070FA	T250FJ
90	JGHDC3090FAG	JGHDC3250NN	JT3090FA	T250FJ
100	JGHDC3100FAG	JGHDC3250NN	JT3100FA	T250FJ
125	JGHDC3125FAG	JGHDC3250NN	JT3125FA	T250FJ
150	JGHDC3150FAG	JGHDC3250NN	JT3150FA	T250FJ
175	JGHDC3175FAG	JGHDC3250NN	JT3175FA	T250FJ
200	JGHDC3200FAG	JGHDC3250NN	JT3200FA	T250FJ
225	JGHDC3225FAG	JGHDC3250NN	JT3225FA	T250FJ
250	JGHDC3250FAG	JGHDC3250NN	JT3250FA	T250FJ

HJDDC3250



Type HJDDC DC Circuit Breakers— Three-Pole High Interrupting Capacity 42 kAIC at 600 Vdc

Maximum Continuous Ampere Rating at 40 °C	Circuit Breaker Frame Only ^① Catalog Number	Thermal-Magnetic Trip Unit Catalog Number	Standard Terminals Catalog Number
70	HJDDC3250F	JT3070T	TA250KB
90	HJDDC3250F	JT3090T	TA250KB
100	HJDDC3250F	JT3100T	TA250KB
125	HJDDC3250F	JT3125T	TA250KB
150	HJDDC3250F	JT3150T	TA250KB
175	HJDDC3250F	JT3175T	TA250KB
200	HJDDC3250F	JT3200T	TA250KB
225	HJDDC3250F	JT3225T	TA250KB
250	HJDDC3250F	JT3250T	TA250KB

Note

^① For complete breaker, order individual frame, trip unit and terminals for field installation.

HKDDC3400

**Type HKDDC DC Circuit Breakers—
Three-Pole High Interrupting Capacity 42 kAIC at 600 Vdc**

Maximum Continuous Ampere Rating at 40 °C	Circuit Breaker Frame Only ^① Catalog Number	Thermal-Magnetic Trip Unit Catalog Number	Standard Terminals Catalog Number
100	HKDDC3400F	KT3100T	TA300K
125	HKDDC3400F	KT3125T	TA300K
150	HKDDC3400F	KT3150T	TA300K
175	HKDDC3400F	KT3175T	TA300K
200	HKDDC3400F	KT3200T	TA300K
225	HKDDC3400F	KT3225T	TA300K
250	HKDDC3400F	KT3250T	TA350K
300	HKDDC3400F	KT3300T	TA350K
350	HKDDC3400F	KT3350T	TA350K
400	HKDDC3400F	KT3400T	3TA400K ^②

LGEDC3630NN

**Type LGEDC DC Circuit Breakers—
Three-Pole High Interrupting Capacity 35 kAIC at 600 Vdc**

Maximum Continuous Ampere Rating at 40 °C	Complete Breaker Catalog Number	Circuit Breaker Frame Only ^① Catalog Number	Thermal-Magnetic Trip Unit Catalog Number	Standard Terminals Catalog Number
250	LGEDC3250FAG	LGEDC3630NN	LT3250FA	TA350LK
300	LGEDC3300FAG	LGEDC3630NN	LT3300FA	TA350LK
350	LGEDC3350FAG	LGEDC3630NN	LT3350FA	TA350LK
400	LGEDC3400FAG	LGEDC3630NN	LT3400FA	TA350LK
500	LGEDC3500FAG	LGEDC3630NN	LT4500FA	3TA632LK ^②
600	LGEDC3600FAG	LGEDC3630NN	LT3600FA	3TA632LK ^②

**Type LGSDC DC Circuit Breakers—
Three-Pole High Interrupting Capacity 50 kAIC at 600 Vdc**

Maximum Continuous Ampere Rating at 40 °C	Complete Breaker Catalog Number	Circuit Breaker Frame Only ^① Catalog Number	Thermal-Magnetic Trip Unit Catalog Number	Standard Terminals Catalog Number
250	LGSDC3250FAG	LGSDC3630NN	LT3250FA	TA350LK
300	LGSDC3300FAG	LGSDC3630NN	LT3300FA	TA350LK
350	LGSDC3350FAG	LGSDC3630NN	LT3350FA	TA350LK
400	LGSDC3400FAG	LGSDC3630NN	LT3400FA	TA350LK
500	LGSDC3500FAG	LGSDC3630NN	LT4500FA	3TA632LK ^②
600	LGSDC3600FAG	LGSDC3630NN	LT3600FA	3TA632LK ^②

Notes

- ① For complete breaker, order individual frame, trip unit and terminals for field installation.
② Three-pole kit.

Type LGHDC DC Circuit Breakers— Three-Pole High Interrupting Capacity 65 kAIC at 600 Vdc

Maximum Continuous Ampere Rating at 40 °C	Complete Breaker Catalog Number	Circuit Breaker Frame Only ^① Catalog Number	Thermal-Magnetic Trip Unit Catalog Number	Standard Terminals Catalog Number
250	LGHDC3250FAG	LGHDC3630NN	LT3250FA	TA350LK
300	LGHDC3300FAG	LGHDC3630NN	LT3300FA	TA350LK
350	LGHDC3350FAG	LGHDC3630NN	LT3350FA	TA350LK
400	LGHDC3400FAG	LGHDC3630NN	LT3400FA	TA350LK
500	LGHDC3500FAG	LGHDC3630NN	LT4500FA	3TA632LK ^②
600	LGHDC3600FAG	LGHDC3630NN	LT3600FA	3TA632LK ^②

HLDDC



Type HLDDC DC Circuit Breakers— Three-Pole High Interrupting Capacity 35 kAIC at 600 Vdc

Maximum Continuous Ampere Rating at 40 °C	Circuit Breaker Frame Only ^① Catalog Number	Thermal-Magnetic Trip Unit Catalog Number	Standard Terminals Catalog Number
300	HLDDC3600F	LT3300T	TA602LD
350	HLDDC3600F	LT3350T	TA602LD
400	HLDDC3600F	LT3400T	TA602LD
450	HLDDC3600F	LT3450T	TA602LD
500	HLDDC3600F	LT3500T	TA602LD
600	HLDDC3600F	LT3600T	3TA603LDK ^②

Type HLDDC DC Circuit Breakers— Two-Pole High Interrupting Capacity 50 kAIC at 250 Vdc ^{③④}

Maximum Continuous Ampere Rating at 40 °C	Complete Breaker Catalog Number
600	HLDDC20600
700	HLDDC20700
800	HLDDC20800
900	HLDDC20900
1000	HLDDC21000
1200	HLDDC21200

Notes

- ① For complete breaker, order individual frame, trip unit and terminals for field installation.
- ② Three-pole kit.
- ③ Includes breaker frame, trip unit and terminals.
- ④ Four-pole breaker with two poles wired in parallel.

HMDLDC3800F

**Type HMDLDC DC Circuit Breakers—
Three-Pole High Interrupting Capacity 35 kAIC at 600 Vdc**

Maximum Continuous Ampere Rating at 40 °C	Circuit Breaker Frame Only ^① Catalog Number	Thermal-Magnetic Trip Unit Catalog Number	Standard Terminals Catalog Number
300	HMDLDC3800F	MT3300T	TA700MA1
350	HMDLDC3800F	MT3350T	TA700MA1
400	HMDLDC3800F	MT3400T	TA700MA1
450	HMDLDC3800F	MT3450T	TA700MA1
500	HMDLDC3800F	MT3500T	TA700MA1
600	HMDLDC3800F	MT3600T	TA700MA1
700	HMDLDC3800F	MT3700T	TA700MA1
800	HMDLDC3800F	MT3800T	TA800MA2

**Type NBDC DC Circuit Breakers—
Three-Pole High Interrupting Capacity 50 kAIC at 600 Vdc**

Maximum Continuous Ampere Rating at 40 °C	Complete Circuit Breaker Factory Assembled without Terminals ^② Catalog Number	Includes Magnetic Trip Unit Calibrated at 135%	Standard Terminals Catalog Number
700	NBDC3700MW	Included	TA1000NB1
800	NBDC3800MW	Included	TA1000NB1
900	NBDC3900MW	Included	TA1000NB1
1000	NBDC31000MW	Included	TA1000NB1
1200	NBDC31200MW	Included	TA1200NB1

RGHDC3300FFWM

**Type RGHDC DC Circuit Breakers—
Three-Pole High Interrupting Capacity 65 kAIC at 600 Vdc**

Maximum Continuous Ampere Rating at 40 °C	Complete Circuit Breaker Factory Assembled ^②		Includes Magnetic Trip Unit Calibrated at 135%
	Imperial Termination Threading Catalog Number	Metric Termination Threading Catalog Number	
1600	RGHDC3160FFWE	RGHDC3160FFWM	Included
2000	RGHDC3200FFWE	RGHDC3200FFWM	Included
2500	RGHDC3250FFWE	RGHDC3250FFWM	Included
3000	RGHDC3300FFWE	RGHDC3300FFWM	Included

Notes

^① Includes frame and trip unit. Order terminals or connectors separately.

^② Six rear connectors included as standard that match terminal threading.

DC Breaker Terminal Wire Ranges

Breaker Frame	Maximum Breaker Ampacity	Terminal Body Material	Wire Type	AWG Wire Range/ Number of Conductors	Metric Wire Range mm ²	Number of Terminals Included	Standard Terminal Catalog Number
EGEDC, EGSDC, EGHDC	100	Aluminum	Cu/Al	14–1/0	2.5–50	3	3TA125EF
HFDDC	20	Steel	Cu/Al	14–10 (1)	2.5–4 (1)	3	3T20FB
	100	Steel	Cu/Al	14–1/0 (1)	2.5–50 (1)	3	3T100FB
	225	Aluminum	Cu/Al	4–4/0 (1)	25–95 (1)	3	3TA225FD
	250	Stainless steel	Cu	4–350 (1)	25–185 (1)	1	T250FJ
HJDDC	250	Aluminum	Cu/Al	4–350 kcmil (1)	25–185 (1)	1	TA250KB
HKDDC	225	Aluminum	Cu/Al	3–350 kcmil (1)	35–185 (1)	1	TA300K
	350	Aluminum	Cu/Al	250–500 kcmil (1)	120–240 (1)	1	TA350K
	400	Aluminum	Cu/Al	3/0–250 kcmil (2)	95–120 (1)	3	3TA400K
LGEDC, LGSDC, LGHDC	400	Aluminum	Cu/Al	2–500 (1)	35–240 (1)	1	TA350LK
	630	Aluminum	Cu/Al	2–500 kcmil (2)	35–240 (2)	1	TA632L
	630	Aluminum	Cu/Al	2–500 kcmil (2)	35–240 (2)	3	3TA632LK
HLDDC	500	Aluminum	Cu/Al	3/0–350 kcmil (2)	95–150 (2)	1	TA602LD
	600	Aluminum	Cu/Al	400–500 kcmil (2)	185–240 (2)	3	3TA603LDK
HMDLDC	600	Aluminum	Cu/Al	1–500 kcmil (2)	—	1	TA700MA1
	800	Aluminum	Cu/Al	3/0–400 kcmil (3)	—	1	TA800MA2
NBDC	700	Aluminum	Cu/Al	3/0–400 kcmil (3)	95–185 (3)	1	TA1000NB1
	800	Aluminum	Cu/Al	3/0–400 kcmil (3)	95–185 (3)	1	TA1000NB1
	900	Aluminum	Cu/Al	3/0–400 kcmil (3)	95–185 (3)	1	TA1000NB1
	1000	Aluminum	Cu/Al	3/0–400 kcmil (3)	95–185 (3)	1	TA1000NB1
	1200	Aluminum	Cu/Al	4/0–500 kcmil (4)	120–240 (4)	1	TA1200NB1

Note: RGHDC breakers include six rear connectors as standard.

Molded Case Switches

Eaton's DC molded case switches are used in applications requiring a compact, high-capacity disconnect. They are UL 489 listed and have automatic high instantaneous current protection. These devices do not provide overload protection.

Molded Case Switches

Maximum Continuous Ampere Rating at 40 °C	Interrupting Capacity (Volts DC)	Poles in Series	With Line and Load Terminals	Without Line and Load Terminals
			Catalog Number	Catalog Number
600 Vdc Maximum				
100	42	3	HFDDC3100KL	HFDDC3100KW
150	42	3	HFDDC3150KL	HFDDC3150KW
225	42	3	HFDDC3225KL	HFDDC3225KW
250	65	3	JGKDC3250KSG	JGKDC3250KSW
250	42	3	HJDDC3250K	HJDDC3250KW
			400	35
400	65	3	LGKDC3400KSG	LGKDC3400KSW
			600	65
600	35	3	HLDDC3600K	HLDDC3600WK
			800	35
500 Vdc Maximum				
100	65	3	EGK3100KSG	EGK3100KSW
250 Vdc Maximum				
100	50	2	HFDDC2100KL	HFDDC2100KW
150	50	2	HFDDC2150KL	HFDDC2150KW
225	50	2	HFDDC2225KL	HFDDC2225KW
1200	50	①	HLDDC21200K ①	HLDDC21200WK ①

Note

① Four-pole frame with two-pole connected in parallel.

Accessories

Internal Accessories

Description	Factory Installation (HFDDC)	Field Installation Kits								
		HFDDC ①	EGEDC, EGSDC, EGHDC	JGEDC, JGSDC, JGHDC	LGEDC, LGSDC, LGHDC	HJDDC	HKDDC	HLDDC	HMDLDC	NBDC
Right-Pole Mounting										
Auxiliary switch										
1A-1B	A06	A1X1PK	AUX1A1BPK	AUX1A1BPK	A1X2PK	A1X3PK	A1X4PK	A1X4PK	4980D16G05	—
2A-2B	A13	A2X1RPK	AUX2A2BPK	AUX2A2BPK	A2X2PK	A2X3PK	A2X4PK	A2X4PK	4980D16G06	A2X6RPK
Alarm switch										
1 make/1 break	B06	A1L1RPK	ALM1M1BEPK	ALM1M1BJPK	A1L2RPK	A1L3RPK	A1L4RPK	A1L4RPK	—	A1L6RPK
Auxiliary and alarm combo										
1A-1B, 1 make/1 break	C05	AAL1RPK	AUXALRMEPK	AUXALRMJPK	AAL2RPK	AAL3RPK	AA114RPK	AA114RPK	—	—
Left-Pole Mounting										
Shunt trip										
12 Vdc	S02	SNT1LP03K	SNT012CPK	SNT012CPK	SNT2P04K	SNT3P04K	SNT4LP03K	SNT4LP03K	2606D58G14	—
24 Vdc	S02	SNT1LP03K	SNT024CPK	SNT024CPK	SNT2P04K	SNT3P04K	SNT4LP03K	SNT4LP03K	2606D58G13	SNT6P03K ②
48 Vdc	S06	SNT1LP08K	SNT4860CPK	SNT4860CPK	SNT2P06K	SNT3P06K	SNT4LP23K	SNT4LP23K	2606D58G12	SNT6P23K ②
60 Vdc	S06	SNT1LP08K	SNT4860CPK	SNT4860CPK	SNT2P06K	SNT3P06K	SNT4LP23K	SNT4LP23K	2606D58G11	SNT6P23K ②
125 Vdc	S10	SNT1LP12K	SNT120CPK	SNT120CPK	SNT2P11K	SNT3P11K	SNT4LP26K	SNT4LP26K	2606D58G10	SNT6P23K ②
250 Vdc	S14	SNT1LP18K	—	—	SNT2P14K	SNT3P14K	SNT4LP14K	SNT4LP14K	2606D58G09	SNT6P14K
120 Vac	S06	SNT1LP12K	SNT120CPK	SNT120CPK	SNT2P11K	SNT3P11K	SNT4LP11K	SNT4LP11K	2060D58G05	SNT6P11K ②
Undervoltage release										
12 Vdc	U30	UVH1LP20K	UVR012DPK	UVR012DPK	UVH2LP20K	UVH3LP20K	UVH4LP20K	UVH4LP20K	372D032G06	UVH6RP20K ②
24 Vdc	U34	UVH1LP21K	UVR024DPK	UVR024DPK	UVH2LP21K	UVH3LP21K	UVH4LP21K	UVH4LP21K	372D032G07	UVH6RP21K ②
48 Vdc	U38	UVH1LP22K	UVR048DPK	UVR048DPK	UVH2LP22K	UVH3LP22K	UVH4LP22K	UVH4LP22K	372D032G08	UVH6RP23K ②
125 Vdc	U42	UVH1LP26K	UVR125DPK	UVR125DPK	UVH2LP26K	UVH3LP26K	UVH4LP26K	UVH4LP26K	372D032G09	UVH6RP26K ②
250 Vdc	U46	UVH1LP28K	UVR250DPK	UVR250DPK	UVH2LP28K	UVH3LP28K	UVH4LP28K	UVH4LP28K	372D032G10	UVH6RP28K ②
120 Vac	U14	UVH1LP08K	UVR120APK	UVR120APK	UVH2LP08K	UVH3LP08K	UVH4LP08K	UVH4LP08K	373D632G05	UVH6RP08K ②

Notes

① F-Frame circuit breakers are factory sealed. Underwriters Laboratories requires that internal accessories be installed at the factory. Internal accessories are UL listed for factory installation under E7819. Where local codes and standards permit and UL listing is not required, internal accessories can be field installed. Accessory installation should be done before the circuit breaker is mounted and connected.

② Right-pole mounted.

One accessory can be mounted per pole, per breaker. Factory installation of accessories is available. Contact Eaton for assistance with part number configuration.

Jumpers

Jumpers must be ordered separately. Priced individually.

2

HFDDC Frame

Description	Maximum Amperes	Catalog Number
Single copper jumper	60	DC1F060 ^①
	100	DC1F100 ^①
	125	DC1F125 ^①
	225	DC1F225 ^①
Package of 2 aluminum jumpers	100	DC2FD100A
Package of 3 aluminum jumpers	100	DC3FD100A

JGEDC, JGSDC, JGHDC Frames

Description	Maximum Amperes	Catalog Number
Single aluminum jumper	250	DC1JG250A ^①
Package of 2 aluminum jumpers	250	DC2JG250A ^①
Package of 20 aluminum jumpers	250	DC20JG250A ^①

HKDDC Frame

Description	Maximum Amperes	Catalog Number
Single copper jumper	400	DC1K400 ^①
Package of 2 aluminum jumpers	400	DC2KD400A ^①
Package of 3 aluminum jumpers	400	DC3KD400A ^①

LGEDC, LGSDC, LGHDC Frames

Description	Maximum Amperes	Catalog Number
Package of 2 aluminum jumpers	400	DC2LG400A
Package of 3 aluminum jumpers	400	DC3LG400A
Package of 30 aluminum jumpers	400	DC30LG400A

Note

^① Not UL Listed; Non UL listed jumpers used in a UL application may need to be qualified by the OEM in their assembly. This may take place with UL or another certified testing agency.

Wiring Diagrams

Series Connection Diagrams for DC Application ①②

250 Vdc Maximum—Two Poles in Series

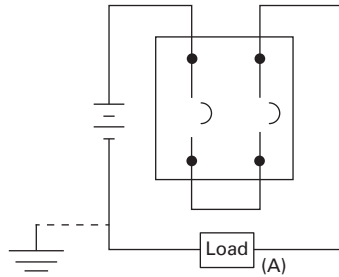

Suitable for use on ungrounded systems, or grounded systems that have one end of load (A) connected to grounded terminal, opposite poles in series connection.

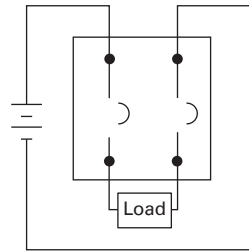

Suitable for use on ungrounded systems only.

500 Vdc or 600 Vdc Maximum—Three Poles in Series

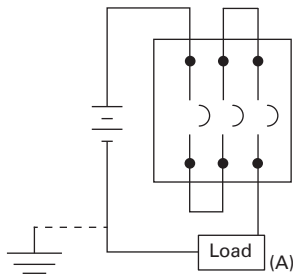

Suitable for use on ungrounded systems, or grounded systems that have one end of load (A) connected to grounded terminal, opposite poles in series connection.

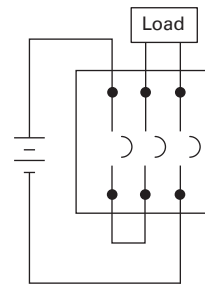

Suitable for use on ungrounded systems only.

750 Vdc Maximum—Four Poles in Series

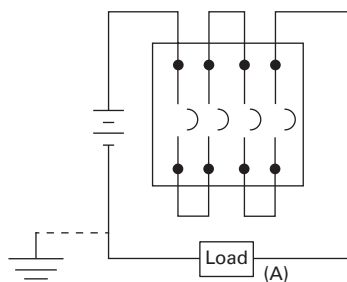

Suitable for use on ungrounded systems, or grounded systems that have one end of load (A) connected to grounded terminal, opposite poles in series connection.

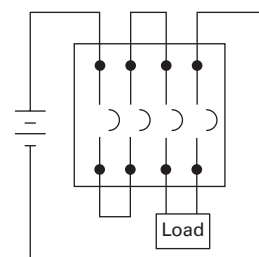

Suitable for use on ungrounded systems only.

Notes

- ① Poles in series connection is customer supplied. Use rated cable per NEC.
- ② For grounded systems, all poles in series must be connected on non-grounded terminal, with load connected to grounded terminal.

Dimensions

Approximate Dimensions in Inches (mm)

2

DC Breaker Dimensions

Frame	Number of Poles	Width	Height	Depth
EGEDC, EGSDC, EGHDC	3	3.00 (76.2)	5.50 (139.7)	2.99 (75.9)
HFDDC	1	1.38 (35.1)	6.00 (152.4)	3.38 (86.0)
	2	2.75 (70.0)	6.00 (152.4)	3.38 (86.0)
	3	4.13 (105.0)	6.00 (152.4)	3.38 (86.0)
	4	5.50 (139.7)	6.00 (152.4)	3.38 (86.0)
JGEDC, JGSDC, JGHDC	3	4.13 (104.9)	7.00 (177.8)	3.57 (90.7)
HJDDC	2, 3	4.13 (105.0)	10.00 (254.0)	4.06 (103.1)
HKDDC	2, 3	5.50 (139.7)	10.13 (257.3)	4.10 (104.1)
LGEDC, LGSDC, LGHDC	3	5.48 (139.2)	10.13 (257.3)	4.09 (103.9)
600 A Max. HLDDC	2, 3	8.25 (209.6)	10.75 (273.1)	4.06 (103.1)
1200 A Max. HLDDC	4	11.00 (279.4)	10.75 (273.1)	4.06 (103.1)
HMDLDC	2, 3	8.25 (209.6)	16.00 (406.4)	4.06 (103.1)
NBDC	3	8.25 (209.6)	16.00 (406.4)	5.50 (139.7)
RGHDC	3	15.50 (393.7)	16.00 (406.4)	9.75 (247.7)

PVGard Solar Photovoltaic Circuit Breakers



600 Vdc Per-Pole



1000 Vdc Poles-in-Series

Contents

Description

	Page
Engine Generator Circuit Breakers	V4-T2-437
Direct Current Circuit Breakers	V4-T2-443
PVGard Solar Circuit Breakers—600 Vdc Per-Pole and 1000 Vdc Poles-in-Series	
Application Description	V4-T2-458
Features	V4-T2-458
Standards and Certifications	V4-T2-458
Product Selection	V4-T2-459
Accessories	V4-T2-461
Technical Data and Specifications	V4-T2-465
Dimensions	V4-T2-468
Wiring Diagrams	V4-T2-469
E ² Mining Service Circuit Breakers	V4-T2-470

PVGard Solar Circuit Breakers—600 Vdc Per-Pole and 1000 Vdc Poles-in-Series**Product Overview**

- Two PVGard lineups
 - 600 Vdc per-pole breaker and switch. Each pole rated 600 Vdc
 - 1000 Vdc poles-in-series breaker and switch. Requires poles in series connection
- Both options UL 489B listed for solar photovoltaic circuit protection
- 50 °C calibration
- Offers both 100% and 80% rated breakers
- Handle bi-directional current flow

Product Description

Photovoltaic (PV) systems convert the energy of the sun into electrical power that is fed directly into the electric grid. Within the balance of system (BOS), direct current (DC) circuit breakers protect the wiring connected from the PV modules to the combiner or the inverter, while also behaving as a disconnect.

Eaton is a global leader in circuit protection and brings this expertise to bear in the photovoltaic market. PVGard solar circuit breakers are part of a product family that combines a disconnect with circuit protection in a single, compact, resettable device to protect and isolate DC circuits as needed in photovoltaic systems. PVGard breakers can replace fuses, fuse holders and disconnects in combiner box and inverter applications—saving space, streamlining design, purchasing and receiving, and reducing spare parts requirements.

There are two PVGard lineups to choose from: the industry-exclusive, 600 Vdc per-pole breakers and switches designed for residential and light commercial applications and 1000 Vdc poles-in-series breakers and switches for commercial and utility scale applications.

PVGard 600 Vdc Per-Pole Lineup

Only Eaton can offer this breakthrough breaker that will save significant space, time and cost. As a single-circuit-per-pole device, it allows space savings of up to 66% when compared to traditional poles-in-series disconnects, switches and breakers. In addition, it eliminates the need for jumpers for poles-in-series connection—saving on installation time, labor and even inventory.

PVGard 1000 Vdc Poles-in-Series Lineup

This 1000 Vdc poles-in-series lineup provides reliable and safe disconnect means and overcurrent protection in a single, compact device for commercial and utility scale PV systems. This solution does not require jumpers with the breaker/switch to be a UL 489B listed device, providing reliability and flexibility in design without limitation on implementation of the breaker/switch. If needed, cost-effective Eaton jumpers can be included.

Application Description

Photovoltaic (PV) systems convert the energy of the sun into electrical power that is fed directly into the electric grid. PVGuard circuit breakers are used to protect the wiring from the modules to the combiner box or inverter from overcurrents, and to provide an isolation mechanism.

Eaton offers a complete line of UL 489 Listed multi-purpose 600 Vdc poles-in-series breakers and switches, as well as protection for the AC side of the inverter. Refer to **Page V4-T2-443** for 600 Vdc breakers and **Page V4-T2-110** for AC breaker selection.

Features

PVGuard breakers are uniquely designed with these features:

- Meets the higher voltage and lower fault current levels of solar systems
- Tested to extreme ambient conditions from -40°C to $+90^{\circ}\text{C}$
- Full complement of accessories for status, signalling, and on/off operation remotely
- Can handle bi-directional flow of current
- Can be applied in grounded, ungrounded or bi-polar systems
- Meets and exceeds the standards of UL 489B for photovoltaic molded case circuit breakers and molded case switches
- Available both standard (80%-rated) and 100%-rated breakers
- 50°C calibration
- Ability to open on signal from DC arc or ground fault detector
- Wide range of current ratings increases options for matching incoming strings
- Eliminates fuse stocking costs and matching issues

Designed specifically for high- and low-temperature demands of PV installations, PVGuard circuit breakers undergo extreme ambient cycling tests, and carry a robust operating temperature range. Trip units calibrate at 100% and 80% of nameplate current in a 50°C ambient, ensuring continuous operation in higher temperature environments typical to solar.

Rigorous third-party testing includes limited and standard fault current tests, electrical and mechanical endurance, dielectric voltage withstand and temperature tests. Eaton's PVGuard products are stand-alone devices without requiring jumpers to be UL 489B listed devices.

PVGuard breakers are available with a full complement of accessories to provide string status, enable remote trip, on/off operation, and can be customized to site requirements.

Standards and Certifications

- Designed to meet UL 489B for solar photovoltaic circuit protection
- UL File E350638, Category Control Number DIUR



Product Selection

Catalog number includes breaker frame and trip unit. Order terminals separately. See **Page V4-T2-463**.
For complete internal and external accessories, see accessory section of each frame.

JG PVS Frame**JG PVS Frame, 250 A Maximum, 600 Vdc Per Pole, 1.2 kA** ^①

Current Rating Amperes	Number Poles/ 600 Vdc Circuits	Trip Unit	80% Rated Catalog Number	100% Rated Catalog Number
90	3	Fixed thermal, fixed magnetic	JGPVS3090W	CJGPVS3090W
100	3	Fixed thermal, fixed magnetic	JGPVS3100W	CJGPVS3100W
125	3	Fixed thermal, fixed magnetic	JGPVS3125W	CJGPVS3125W
150	3	Fixed thermal, fixed magnetic	JGPVS3150W	CJGPVS3150W
175	3	Fixed thermal, fixed magnetic	JGPVS3175W	CJGPVS3175W
200	3	Fixed thermal, fixed magnetic	JGPVS3200W	CJGPVS3200W
225	3	Fixed thermal, fixed magnetic	JGPVS3225W	CJGPVS3225W
250	3	Fixed thermal, fixed magnetic	JGPVS3250W	CJGPVS3250W

KD PVS Frame**KD PVS Frame, 400 A Maximum, 600 Vdc Per Pole, 3 kA** ^①

Current Rating Amperes	Number Poles/ 600 Vdc Circuits	Trip Unit	80% Rated Catalog Number	100% Rated Catalog Number
100	3	Fixed thermal, fixed magnetic	KDPVS3100W	CKDPVS3100W
125	3	Fixed thermal, fixed magnetic	KDPVS3125W	CKDPVS3125W
150	3	Fixed thermal, fixed magnetic	KDPVS3150W	CKDPVS3150W
175	3	Fixed thermal, fixed magnetic	KDPVS3175W	CKDPVS3175W
200	3	Fixed thermal, fixed magnetic	KDPVS3200W	CKDPVS3200W
225	3	Fixed thermal, fixed magnetic	KDPVS3225W	CKDPVS3225W
250	3	Fixed thermal, fixed magnetic	KDPVS3250W	CKDPVS3250W
300	3	Fixed thermal, fixed magnetic	KDPVS3300W	CKDPVS3300W
350	3	Fixed thermal, fixed magnetic	KDPVS3350W	CKDPVS3350W
400	3	Fixed thermal, fixed magnetic	KDPVS3400W	CKDPVS3400W

Note

^① Terminals not included with frames.

2.5

Molded Case Circuit Breakers

Specialty Breakers

2

Catalog number includes breaker frame and trip unit. Order terminals separately. See **Page V4-T2-463**.

FD PV Frame



FD PV Frame, 100 A Maximum, 1000 Vdc, 3 kA ①

Current Rating Amperes	Poles in Series	Trip Unit	80% Rated Catalog Number	100% Rated Catalog Number
30	4	Fixed thermal, fixed magnetic	FDPV4030W	CFDPV4030W
40	4	Fixed thermal, fixed magnetic	FDPV4040W	CFDPV4040W
50	4	Fixed thermal, fixed magnetic	FDPV4050W	CFDPV4050W
60	4	Fixed thermal, fixed magnetic	FDPV4060W	CFDPV4060W
70	4	Fixed thermal, fixed magnetic	FDPV4070W	CFDPV4070W
80	4	Fixed thermal, fixed magnetic	FDPV4080W	CFDPV4080W
90	4	Fixed thermal, fixed magnetic	FDPV4090W	CFDPV4090W
100	4	Fixed thermal, fixed magnetic	FDPV4100W	CFDPV4100W

KD PV Frame



KD PV Frame, 350 A Maximum, 1000 Vdc, 5 kA ①

Current Rating Amperes	Poles in Series	Trip Unit	80% Rated Catalog Number	100% Rated Catalog Number
125	4	Fixed thermal, fixed magnetic	KDPV4125W	CKDPV4125W
150	4	Fixed thermal, fixed magnetic	KDPV4150W	CKDPV4150W
175	4	Fixed thermal, fixed magnetic	KDPV4175W	CKDPV4175W
200	4	Fixed thermal, fixed magnetic	KDPV4200W	CKDPV4200W
225	4	Fixed thermal, fixed magnetic	KDPV4225W	CKDPV4225W
250	4	Fixed thermal, fixed magnetic	KDPV4250W	CKDPV4250W
300	4	Fixed thermal, fixed magnetic	KDPV4300W	CKDPV4300W
350	4	Fixed thermal, fixed magnetic	KDPV4350W	CKDPV4350W

LG PV Frame



LG PV Frame, 400 A Maximum, 1000 Vdc, 5 kA ①

Current Rating Amperes	Poles in Series	Trip Unit	80% Rated Catalog Number	100% Rated Catalog Number
250	4	Fixed thermal, fixed magnetic	LGPV4250W	CLGPV4250W
300	4	Fixed thermal, fixed magnetic	LGPV4300W	CLGPV4300W
350	4	Fixed thermal, fixed magnetic	LGPV4350W	CLGPV4350W
400	4	Fixed thermal, fixed magnetic	LGPV4400W	CLGPV4400W

MDL PV Frame



MDL PV Frame, 600 A Maximum, 1000 Vdc, 7.5 kA ①

Current Rating Amperes	Poles in Series	Trip Unit	80% Rated Catalog Number	100% Rated Catalog Number
300	3	Fixed thermal, fixed magnetic	MDLPV3300W	CMDLPV3300W
350	3	Fixed thermal, fixed magnetic	MDLPV3350W	CMDLPV3350W
400	3	Fixed thermal, fixed magnetic	MDLPV3400W	CMDLPV3400W
450	3	Fixed thermal, fixed magnetic	MDLPV3450W	CMDLPV3450W
500	3	Fixed thermal, fixed magnetic	MDLPV3500W	CMDLPV3500W
600	3	Fixed thermal, fixed magnetic	MDLPV3600W	CMDLPV3600W

Note

① Terminals not included with frames.

Accessories

Available Accessories

- Auxiliary switch
- Shunt trip
- Electrical operator
- Alarm lockout
- Undervoltage release
- Terminals
- Lock-off devices
- End cap kits
- Rotary handle mechanisms
- Flexible shaft handle mechanisms

Optional modifications

- Freeze testing

For complete internal and external accessories, see the accessory section of each frame.

External Accessories

Description	Frame	Catalog Number
Imperial Base Mounting Hardware		
0.164-32 x 1.5-inch pan-head steel screws and lockwashers	FD PV	BMH1
0.250-20 x 1.5 inch pan-head steel screws and lockwashers	KD PV KD PVS	BMH3
—	JG PVS	N/A
—	LG PV	N/A
0.3125-18 x 1.25 inch filister-head steel screws and lockwashers and flat washers	MDL PV	BMH5
Metric Base Mounting Hardware		
M4-0.7 x 38 mm pan-head steel screws and lockwashers	FD PV	BMH1M
M6-0.7 x 38 mm pan-head steel screws and lockwashers	KD PV KD PVS	BMH3M
—	JG PVS	Included ^①
—	LG PV	Included ^①
M8-1.25 x 35 mm pan-head steel screws and lockwashers	MDL PV	BMH5M
Interphase Barriers		
	FD PV	IPB1
	KD PV KD PVS	IPB3
	JG PVS	FJIPBK ^②
	LG PV	IPB3
	MDL PV	IPB4
Non-Padlockable Handle Block		
	FD PV	LKD1
	KD PV KD PVS	LKD3
	JG PVS	N/A
	LG PV	N/A
	MDL PV	LKD4
Padlockable Handle Lock Hasp ^③		
	FD PV	PLK1
	KD PV KD PVS	PLK3
	JG PVS	FJPHL
	LG PV	LPHL
	MDL PV	HLK4

Factory Modifications—Freeze Testing to –40°C ^④

Frame	Modification Code
FD PV	F01
JG PVS	F01
KD PV and KD PVS	F01
LG PV	F01
MDL PV	F01
Special calibration—contact Eaton for availability	

Molded Case Switches

Eaton's DC molded case switches (MCS) are used in applications requiring a compact, high capacity disconnect. PVGuard 1000 Vdc

MCS are UL 489B listed and have automatic instantaneous current protection. These devices do not provide overload protection.

Molded Case Switches

Maximum Continuous Ampere Rating at 50 °C	Interrupting Capacity Vdc	Poles in Series	Catalog Number
1000 Vdc Maximum			
100	3000	4	FDPV4100KW
200	5000	4	KDPV4200KW
250	5000	4	KDPV4250KW
350	5000	4	KDPV4350KW
400	5000	4	LGPV4400KSW
600	7500	3	MDLPV3600KSW

Notes

- ① Base mounting hardware is included with a circuit breaker or a molded case switch (included with breaker). If required separately, order 66A2546G02.
- ② Individually priced.
- ③ Locks in ON and OFF position.
- ④ Add 20% to list price.

Internal Accessories—Right Pole Mounting

	FD PV ①		JG PVS		KD PV KD PVS		LG PV		MDL PV	
	Factory Modification Code	Field Kit Catalog Number	Factory Modification Code	Field Kit Catalog Number	Factory Modification Code	Field Kit Catalog Number	Factory Modification Code	Field Kit Catalog Number	Factory Modification Code	Field Kit Catalog Number
Auxiliary Switch										
1A-1B	A06	A1X1PK	A1	AUX1A1BPK	A06	A1X3PK	A1	AUX1A1BPK	A06	A1X4PK
2A-2B	A13	A2X1RPK	A2	AUX2A2BPK	A13	A2X3PK	A2	AUX2A2BPK	A13	A2X4PK
Alarm Switch										
1 make/1 break	B06	A1L1RPK	B1	ALM1M1BJPKL	B06	A1L3RPK	B1	ALM1M1BJPK	B06	A1L4RPK
Auxiliary and Alarm Combo										
1A-1B, 1 make/1 break	C05	AAL1RPK	B2w	AUXALRMJPK	C05	AAL3RPK	B2	AUXALRMJPK	C05	AA114RPK

Internal Accessories—Left Pole Mounting

	FD PV ①		JG PVS		KD PV KD PVS		LG PV		MDL PV	
	Factory Modification Code	Field Kit Catalog Number	Factory Modification Code	Field Kit Catalog Number	Factory Modification Code	Field Kit Catalog Number	Factory Modification Code	Field Kit Catalog Number	Factory Modification Code	Field Kit Catalog Number
Shunt Trip										
12 Vdc	S02	SNT1LP03K	S4	SNT012CPK	S42	SNT3P04K	S4	SNT012CPK	S02	SNT4LP03K
24 Vdc	S02	SNT1LP03K	S6	SNT024CPK	S42	SNT3P04K	S6	SNT024CPK	S02	SNT4LP03K
48 Vdc	S06	SNT1LP08K	S7	SNT4860CPK	S50	SNT3P06K	S7	SNT4860CPK	S86	SNT4LP23K
60 Vdc	S06	SNT1LP08K	S7	SNT4860CPK	S50	SNT3P06K	S7	SNT4860CPK	S86	SNT4LP23K
125 Vdc	S10	SNT1LP12K	S5	SNT125DPK	S10	SNT3P11K	S2	SNT120CPK	S42	SNT4LP26K
250 Vdc	S14	SNT1LP18K	—	—	S14	SNT3P14K	—	—	S14	SNT4LP14K
120 Vac	S10	SNT1LP12K	S2	SNT120CPK	S10	SNT3P11K	S2	SNT120CPK	S10	SNT4LP11K
Undervoltage Release										
12 Vdc	U30	UVH1LP20K	—	—	T02	UVH3LP20K	U1	UVR012DPK	T02	UVH4LP20K
24 Vdc	U34	UVH1LP21K	U2	UVR024CPK	T02	UVH3LP21K	U2	UVR024DPK	T06	UVH4LP21K
48 Vdc	U38	UVH1LP22K	U4	UVR048DPK	T10	UVH3LP22K	U4	UVR048DPK	T10	UVH4LP22K
60 Vdc	—	—	U4	UVR048DPK	—	—	—	—	—	—
125 Vdc	U42	UVH1LP26K	U6	UVR125DPK	T14	UVH3LP26K	U6	UVR125DPK	T14	UVH4LP26K
250 Vdc	U46	UVH1LP28K	U8	UVR250DPK	T18	UVH3LP28K	U8	UVR250DPK	T18	UVH4LP28K
120 Vac	U14	UVH1LP08K	U5	UVR120APK	U18	UVH3LP08K	U5	UVR120APK	U18	UVH4LP08K

Notes

① Underwriters Laboratories requires that internal accessories for the FD PV be installed at the factory. Internal accessories are UL listed for factory installation under E7819. Where local codes and standards permit and UL listing is not required, internal accessories can be field installed. Accessory installation should be done before the circuit breaker is mounted and connected.

One accessory can be mounted per pole, per breaker.

PVGard Solar Circuit Breaker Terminal Offering

Breaker Frame	Maximum Breaker Ampacity	Terminal Body Material	Wire Type	AWG Wire Range/ Number of Conductors	Metric Wire Range mm ²	Number of Terminals Included	Standard Terminal Catalog Number	Comments
FD PV	50	Steel	Cu/Al	14–4 (1)	2.5–25 (1)	3	3TA50FB	
	100	Aluminum	Cu/Al	6–300 kcmil (1)	16–150 (1)	3	3TA225FDK3	Includes 3P terminal cover
	100	Aluminum	Cu/Al	6–300 kcmil (1)	16–150 (1)	3	3TA225FDK	Includes 3P terminal cover Replacement use only
	100	Copper	Cu	4–4/0 (1)	25–95 (1)	3	3T225FD	
JG PVS	250	Aluminum	Cu/Al	#8–350 kcmil (1)	—	—	TA250FJ	
	250	Aluminum	Cu/Al	(2) 2/0–(2) 4/0	—	①	3TA251FJK1	
	250	Aluminum	Cu/Al	(2) 2/0–(2) 4/0	—	②	3TA251FJK2	
	250	Copper	Cu	#4–350 kcmil (1)	—	—	T250FJ	
KD PV KD PVS	225	Aluminum	Cu/Al	3–350 kcmil (1)	35–185 (1)	1	TA300K	
	250	Aluminum	Cu/Al	250–500 kcmil (1)	120–240 (1)	1	TA350K	
	250	Aluminum	Cu/Al	3/0–250 kcmil (2)	95–120 (1)	4	4TA400K	Contains interphase barriers
	250	Aluminum	Cu/Al	2/0–250 kcmil (2) or 2/0–500 kcmil (1)	70–240 (2)	4	4TA401K	
	300	Aluminum	Cu/Al	3/0–250 kcmil (2)	95–120 (2)	4	4TA401K	Contains interphase barriers
	350	Aluminum	Cu/Al	3/0–250 kcmil (2)	95–120 (2)	4	4TA401K	Contains interphase barriers
	225	Copper	Cu	3–350 kcmil (1)	35–185 (1)	1	T300K	
	250	Copper	Cu	250–500 kcmil (1)	120–240 (1)	1	T350K	
	250	Copper	Cu	3/0–250 kcmil (2)	95–120 (1)	4	4T400K	Contains interphase barriers
	300	Copper	Cu	3/0–250 kcmil (2)	95–120 (2)	4	4TA401K	Contains interphase barriers
LG PV	400	Aluminum	Cu/Al	2–500 kcmil (2)	35–240 (2)	4	4TA632LK	Includes 4P terminal cover
	250	Copper	Cu	2–500 kcmil (1)	35–240 (1)	1	T350LK	
	400	Copper	Cu	2–500 kcmil (2)	35–240 (2)	4	4T632LK	Includes 4P terminal cover
MDL PV	300	Aluminum	Cu/Al	1–500 kcmil (2)	—	1	TA700MA1	
	600	Aluminum	Cu/Al	3/0–400 kcmil (3)	—	1	TA800MA2	

Endcap Kits

Breaker Frame	Number of Poles	Thread Type	Thread Size	Catalog Number
FD PV	4	Imperial	10–32	KPEK14
	4	Metric	M–5	KPEKM14
JG PVS	3	Imperial	—	FJ3RTDK
	3	Metric	—	FJ3RTWK
KD PV	4	Imperial	0.312–18	KPEK34
	4	Metric	M–8	KPEKM34
KD PVS	3	Imperial	—	KPEK3
	3	Metric	—	KPEKM3
LG PV	4	Imperial	—	N/A
	4	Metric	M-10	L4RTWK
MDL PV	3	Imperial	—	—
	3	Metric	—	—

Notes

- ① Three terminals with terminal shield as a kit.
 ② Three terminals with two interphase barriers as a kit.

Jumpers

Jumpers must be ordered separately. Priced individually.

2

FD PV Frame

Description	Maximum Amperes	Catalog Number
Single copper jumper	60	DC1F060 ^①
	100	DC1F100 ^①
	125	DC1F125 ^①
	225	DC1F225 ^①
Package of 2 aluminum jumpers	100	DC2FD100A
Package of 3 aluminum jumpers	100	DC3FD100A

JG PVM, JG PVMD Frames

Description	Maximum Amperes	Catalog Number
Single aluminum jumper	250	DC1JG250A ^①
Package of 2 aluminum jumpers	250	DC2JG250A ^①
Package of 20 aluminum jumpers	250	DC20JG250A ^①

KD PV, KD PVM, KD PVMD Frames

Description	Maximum Amperes	Catalog Number
Single copper jumper	400	DC1K400 ^①
Package of 2 aluminum jumpers	400	DC2KD400A ^①
Package of 3 aluminum jumpers	400	DC3KD400A ^①

LG PV Frame

Description	Maximum Amperes	Catalog Number
Package of 2 aluminum jumpers	400	DC2LG400A
Package of 3 aluminum jumpers	400	DC3LG400A
Package of 30 aluminum jumpers	400	DC30LG400A

Note

^① Not UL Listed; Non UL listed jumpers used in a UL application may need to be qualified by the OEM in their assembly. This may take place with UL or another certified testing agency.

Technical Data and Specifications

- Thermal-magnetic circuit breakers
- Designed to meet UL 489B for solar photovoltaic circuit protection
- 100% rated of the continuous current rating
- 50 °C calibrated
- Can be applied in grounded, ungrounded or bi-polar systems
- Ability to open on signal from DC arc or ground fault detector
- Two PVGard lineups
 - UL File EE350638, Category Control Number DIUR
 - 600 Vdc per-pole breaker and switch
 - Each pole rated 600 Vdc
 - 1000 Vdc poles-in-series breaker and switch
 - Requires poles in series connection

**Quick Reference PVGard Solar Circuit Breakers
600 Vdc Per-Pole****PVGard 600 Vdc Current Ratings by Frame
UL 489B Interrupting Capacity (kA) 600 Vdc Per-Pole**

Circuit Breaker Type	Minimum Amperes	Maximum Amperes	kA Rating
JG PVS	90	250	1.2
KD PVS	100	400	3

**Quick Reference PVGard Solar Circuit Breakers
1000 Vdc Poles-in-Series****PVGard 1000 Vdc Current Ratings by Frame
UL 489B Interrupting Capacity (kA) 1000 Vdc**

Circuit Breaker Type	Minimum Amperes	Maximum Amperes	kA Rating	Poles in Series
FD PV	30	100	3	4
KD PV	125	350	5	4
LG PV	250	400	5	4
MDL PV	300	600	7.5	3

2.5

Molded Case Circuit Breakers

Specialty Breakers

2

PVGard 600 Vdc Per-Pole Solar PV Circuit Breakers (100% and 80% Rated Frames)

	JG PVS	KD PVS
Number of 600 Vdc circuits	3	3
Maximum voltage rating	600 Vdc	600 Vdc
Ampere range	90–250 A	100–400 A
Interrupting capacity at 600 Vdc	1.2 kA	3 kA
Time constant	1 ms	1 ms
Trip unit type	Thermal-magnetic	Thermal-magnetic
Rated impulse withstand voltage		
Main conducting paths	8 kV	8 kV
Auxiliary circuits	4 kV	4 kV
Endurance		
Mechanical operations	10,000	6000
Electrical operations	400	400
Maximum switching frequency	240 per hour	240 per hour
Third-party certification	UL 489B	UL 489B
Environment		
Design ambient temperature	50 °C	50 °C
Maximum current at 60 °C, as % of rated current	93%	93%
Maximum current at 70 °C, as % of rated current	85%	85%
Operating temperature range	–20 °C to +50 °C	–20 °C to +50 °C
Storage temperature range	–20 °C to +70 °C	–20 °C to +70 °C
Suitable for freeze temperatures to –40 °C	Option	Option
Relative humidity	0 to 95% noncondensing	0 to 95% noncondensing
Suitable for reverse-feed applications	Yes	Yes
Mounting—permissible mounting position		

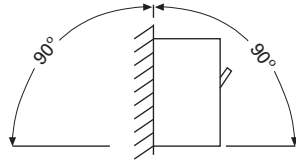

Connection diagrams

Terminations

Al/Cu wire	TA250FJ: (1) #8–350 kcmil	TA300K: (1) #3–350 kcmil
	3TA251FJK1: (2) 2/0–(2) 4/0 ^①	TA350K: (1) 250–500 kcmil
	3TA251FJK2: (2) 2/0–(2) 4/0 ^②	TA403K: (2) 1/0–400 kcmil
Cu wire	T250FJ: (1) #4–350 kcmil	3TA402K: (1) 500–750 kcmil ^③
	T300K: (1) #3–350 kcmil	
Dimensions in inches (mm)		
Height	7.00 (177.8)	10.13 (257.3)
Width	4.13 (104.9)	5.50 (139.7)
Depth	3.57 (90.7)	4.10 (104.1)
Weight in lbs	6.6	11.42

Notes

- ① Three terminals with terminal shield as a kit.
- ② Three terminals with two interphase barriers as a kit.
- ③ Not UL 489B recognized size for maximum of 400 A breaker.

PVGard 1000 Vdc Solar PV Circuit Breakers (100% and 80% Rated Frames)

	FD PV	KD PV	LG PV	MDL PV
Number of poles	4	4	4	3
Maximum voltage rating	1000 Vdc	1000 Vdc	1000 Vdc	1000 Vdc
Maximum current rating	100 A	350 A	400 A	600 A
Interrupting capacity at 1000 Vdc	3 kA	5 kA	5 kA	7.5 kA
Time constant	1 ms	1 ms	1 ms	1 ms
Ampere range	15–100 A	125–350 A	250–400 A	300–600 A
Trip unit type	Thermal-magnetic	Thermal-magnetic	Thermal-magnetic	Thermal-magnetic
Rated impulse withstand voltage				
Main conducting paths	8 kV	8 kV	8 kV	8 kV
Auxiliary circuits	4 kV	4 kV	4 kV	4 kV
Endurance				
Mechanical operations	10,000	10,000	8000	8000
Electrical operations	1000	400	400	400
Maximum switching frequency	300 per hour	240 per hour	240 per hour	240 per hour
Third-party certification	UL 489B	UL 489B	UL 489B	UL 489B
Environment				
Design ambient temperature	50 °C	50 °C	50 °C	50 °C
Maximum current at 60 °C, as % of rated current	91%	91%	93%	93%
Maximum current at 70 °C, as % of rated current	88%	88%	88%	88%
Operating temperature range	–20 °C to +50 °C	–20 °C to +50 °C	–20 °C to +50 °C	–20 °C to +50 °C
Storage temperature range	–20 °C to +70 °C	–20 °C to +70 °C	–20 °C to +70 °C	–20 °C to +70 °C
Suitable for freeze temperatures to –40 °C	Option	Option	Option	Option
Relative humidity	0 to 95% noncondensing	0 to 95% noncondensing	0 to 95% noncondensing	0 to 95% noncondensing
Suitable for reverse-feed applications	Yes	Yes	Yes	Yes
Mounting—permissible mounting position				

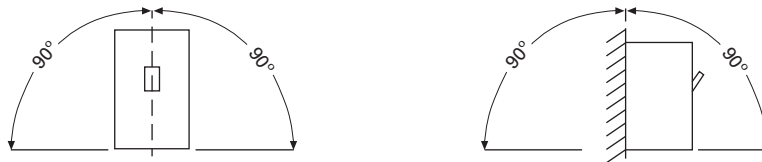

Connection diagrams

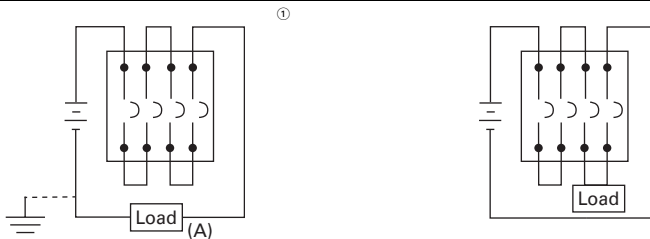

Terminations

Al/Cu wire	#6–300 kcmil	(2) 3/0–250 kcmil	(2) #2–500 kcmil	(3) 3/0–400 kcmil
Cu wire	#4–4/0	(2) 3/0–250 kcmil	(2) #2–500 kcmil	(3) 3/0–300 kcmil
Dimensions in inches (mm)				
Height	6.00 (152.4)	10.13 (257.3)	10.13 (257.3)	16.00 (406.4)
Width	5.50 (139.7)	7.22 (183.4)	7.22 (183.4)	8.25 (209.5)
Depth	3.38 (85.9)	4.09 (103.9)	4.09 (103.9)	4.06 (103.1)
Weight in lbs	6	20	20	29

Notes

- ① Suitable for use on ungrounded systems, or grounded systems that have one end of load (A) connected to grounded terminal, opposite poles in series connection.
- ② Suitable for use on ungrounded systems only.

Dimensions

Approximate Dimensions in Inches (mm)

2

PVGard Solar Circuit Breakers—600 Vdc Per-Pole

Frame	Number of Circuits in a Frame	Width	Height	Depth
JG PVS	3	4.13 (104.9)	7.00 (177.8)	3.44 (87.4)
KD PVS	3	5.49 (139.4)	10.13 (257.2)	4.31 (109.6)

PVGard Solar Circuit Breakers—1000 Vdc Poles-in-Series

Frame	Number of Poles	Width	Height	Depth
FD PV	4	5.50 (139.7)	6.00 (152.4)	3.38 (86.0)
KD PV	4	7.22 (183.4)	10.13 (257.3)	4.09 (103.9)
LG PV	4	7.22 (183.4)	10.13 (257.3)	4.09 (103.9)
MDL PV	3	8.25 (209.6)	16.00 (406.4)	4.06 (103.1)

Wiring Diagrams

Series Connection Diagrams for DC Application ①②

JF PVS, KD PVS—600 Vdc Per-Pole

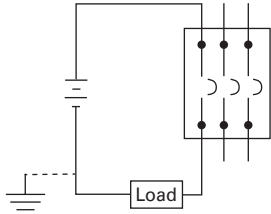

Suitable for grounded or ungrounded systems.
Suitable for quantity (3) 600 Vdc circuits.

FD PV, KD PV, LG PV—1000 Vdc Maximum—Four Poles-in-Series

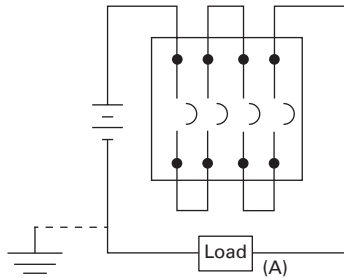

Suitable for use on ungrounded systems, or grounded systems that have one end of load (A) connected to grounded terminal, opposite poles in series connection.

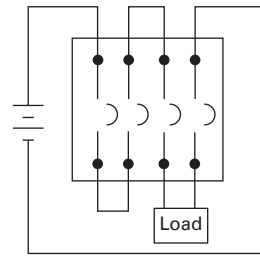

Suitable for use on ungrounded systems only.

MDL PV—1000 Vdc Maximum—Three Poles in Series

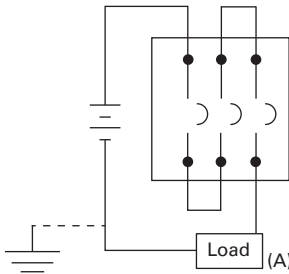

Suitable for use on ungrounded systems, or grounded systems that have one end of load (A) connected to grounded terminal, opposite poles in series connection.

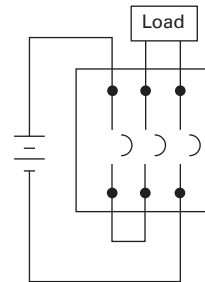

Suitable for use on ungrounded systems only.

Notes

- ① Poles in series connection is customer supplied. Use rated cable per NEC.
- ② For grounded systems, all poles in series must be connected on non-grounded terminal, with load connected to grounded terminal.

E² Mining Service Breakers

2



E² Mining Service Breakers

Product Overview

State-of-the-art E² mining service breakers incorporate the rigid specifications and testing procedures developed by a focus group led by engineers from several large coal companies and Eaton design engineers. Additionally, the performance of these breakers was proven and verified during hundreds of hours of field testing in harsh mine environments.

E² mining breakers are available in 600 Vac, I000Y/577 Vac and 1200 Vac. Interchangeable trip units can be used on either 600 or 1000 Vac frames.

The E² mining breaker family is designed especially for trailing cable application per MSHA 30 CFR 75. Field interchangeable electronic rms sensing trip units are available from 150 to 2000 amperes with instantaneous pickup settings conforming to the code of Federal Regulations 30 CFR 75.601-2. Electromechanical trip units are also available with a wide range of magnetic pickup ranges.

E² electronic trip units are the first to provide the mining industry with true rms sensing, made possible by the custom ASIC microprocessor in each electronic trip unit.

E² breakers are designed to be physically and electrically interchangeable with Classic Mining Service Breakers and supersede Series C[®] Mining Service Breakers. The table to the right outlines direct replacements.

Contents

Description

	<i>Page</i>
Engine Generator Circuit Breakers	V4-T2-437
Direct Current Circuit Breakers	V4-T2-443
PVGard Solar Circuit Breakers—600 Vdc Per-Pole and 1000 Vdc Poles-in-Series	V4-T2-457
E ² Mining Service Breakers	
Catalog Number Selection	V4-T2-472
Product Selection	V4-T2-476
Accessories	V4-T2-487
Dimensions	V4-T2-490

600 Vac Mining Breaker Replacement Chart

Classic	Series C	E ²
FBM	FDBM	E ² F
HFBM	FDM	E ² F
	HFDM (mag. only)	E ² F
—	JDM	E ² J
KAM	KDM	E ² K
KAMH	KDM	E ² K
LAM	LDM	E ² L
LAMH	LDM	E ² L
LCM	LDM	E ² L
LCMH	LDM	E ² L
MAM	—	E ² M
MAMH	—	E ² M
MCM	—	E ² M
MCMH	—	E ² M
NBM	—	E ² N
NBMH	—	E ² N
NCM	—	E ² N
NCMH	—	E ² N

1000 Vac Mining Breaker Replacement Chart

Classic	Series C	E ² M
HFM	—	E ² FM
—	JDCM	E ² JM
HKAM	KDCM	E ² KM
HLAM	LDCM	E ² LM
HLCM	LDCM	E ² LM
HMAM	—	E ² MM
HMCM	—	E ² MM
HNBM	—	E ² NM
HNBMH	—	E ² NM
HNCM	—	E ² NM
HLCLM	—	E ² NM
HPBM	—	E ² RM ①

Additional Information on Mining Breakers

Source	Description
TD01217001E	E ² Mining Circuit Breaker Dimensional Data
BR01217001E	E ² Mining Circuit Breaker Brochure
TC01217001E	E ² Mining Circuit Breaker Time Current Curves
www.eaton.com/mining	Mining and Metals

Note

① E²R/E²RM is a new frame physically different than the HPBM. See DS29-170MS.

Eaton's mining service circuit breakers provide short-circuit protection as specified in the code of Federal Regulations 30 CFR 75.601-2.

E² 225/400 A K frame and 400/600 A L frame electronic trip units feature specifically designed instantaneous pickup settings to conform exactly with the code of Federal Regulations 30 CFR 75.601-2. Electromechanical trip units are also available with a wide range of magnetic pickup ranges.

The tables below list the conductor size maximum allowable circuit breaker instantaneous setting and the E² breaker that meets that setting.

Interrupting Capacity Rating

Circuit Breaker Type	Interrupting Capacity (Symmetrical kA)					Vdc ^①
	Vac (50/60 Hz) 240	480	600	1000Y/577	1200	
E ² F	65	35	18	—	—	10
E ² J	65	35	18	—	—	10
E ² K	65	35	25	—	—	10
E ² LME	100	65	35	—	—	42
E ² L	65	35	25	—	—	22
E ² M	65	35	25	—	—	22
E ² N	65	50	25	—	—	—
E ² R	125	65	50	—	—	—
E ² FM	65	25	18	10	—	10
E ² JM	65	35	18	10	—	22
E ² KM	65	35	25	14	—	10
E ² LMZ	100	65	35	10	—	42
E ² LM	—	35	25	18	—	22
E ² MM	—	35	25	18	—	22
E ² NM ^②	—	50	25	25	—	—
E ² RM	—	65	50	25	—	—
E ² KW	—	—	—	10	10	—
E ² LW	—	—	—	10	10	—
E ² MW	—	—	—	12	12	—

Trailing Cable Setting Per 30 CFR 75

Conductor Size	Maximum Breaker Instantaneous Setting	Maximum Ampere 75 °C Insulated Conductor	E ² /E ² M/E ² W Instantaneous Only	Setting
14	50	15	E ² K 150 A	A
12	75	20	E ² K 150 A	B
10	150	30	E ² K 150 A	C
8	200	50	E ² K 225 A	A
6	300	65	E ² K 225 A	B
4	500	85	E ² K 225 A / E2L 400 A	C/A
3	600	100	E ² K 225 A / E2L 400 A	D/B
2	800	115	E ² K 225 A / E2L 400 A	E/C
1	1000	130	E ² K 225 A / E2L 400 A	F/D
1/0	1250	150	E ² K 225 A / E2L 400 A	G/E
2/0	1500	175	E ² K 225 A / E2L 400 A	H/F
3/0	2000	200	E ² L 400 A	G
4/0	2500	230	E ² L 400 A	H
250	2500	255	E ² L 400 A	H
300	2500	285	E ² L 400 A	H
350	2500	310	E ² L 400 A	H
400	2500	335	E ² L 400 A	H
500	2500	380	E ² L 400 A	H

Auxiliary Switch Electrical Rating Data

Maximum Voltage	Frequency	Maximum Current Amperes
600	50/60 Hz	6.0
125	DC	0.5 (non-inductive load)
250	DC	0.25 (non-inductive load)

Alarm (Signal/Lockout Switch) Electrical Rating Data

Maximum Voltage	Frequency	Maximum Current Amperes
600	50/60 Hz	6.0
125	DC	0.5 (non-inductive load)
250	DC	0.25 (non-inductive load)

Notes

- ① Two poles in series. DC rating applies to breakers with thermal-magnetic trip unit. Breakers with electronic trip units are not DC rated.
- ② Series rated for application with Eaton's E²KM and E²LM breakers.

2.5

Molded Case Circuit Breakers

Specialty Breakers

Catalog Number Selection

This information is presented only as an aid to understanding catalog numbers. It is not to be used to build catalog numbers for circuit breakers or trip units.

2

E² Mining Service Breaker with 310+ Electronic Trip Unit Technology

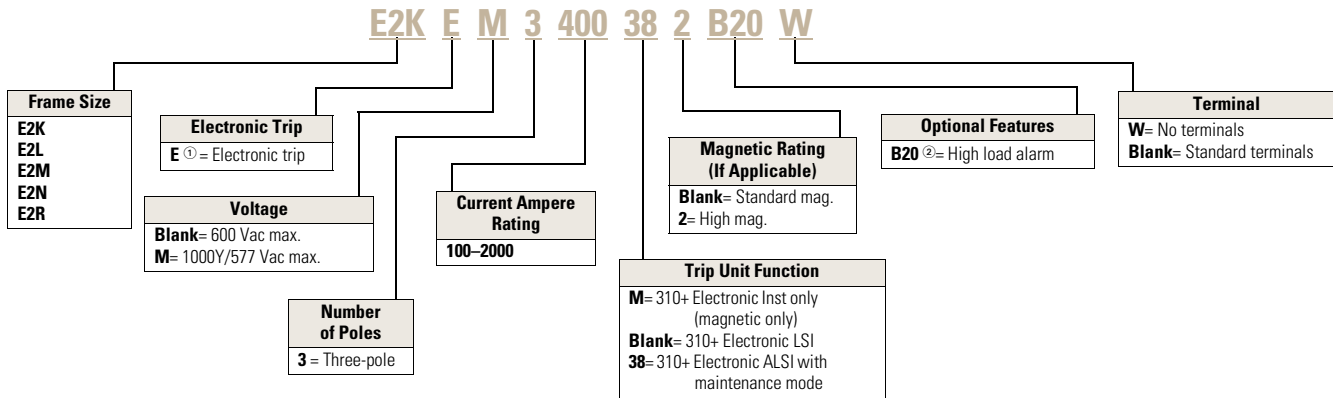

E² Mining Service 310+ Electronic Trip Unit

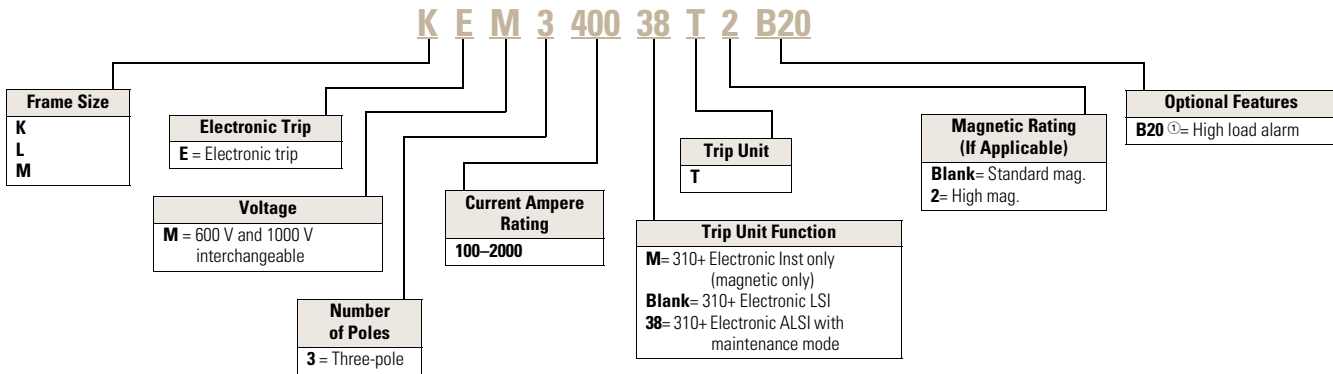

Notes

- ① All N- and R-Frame breakers equipped with 310+ Electronic Trip Unit. No "E" suffix required.
- ② Not available with instantaneous only.

E² Mining Service Breaker Frame Only ①

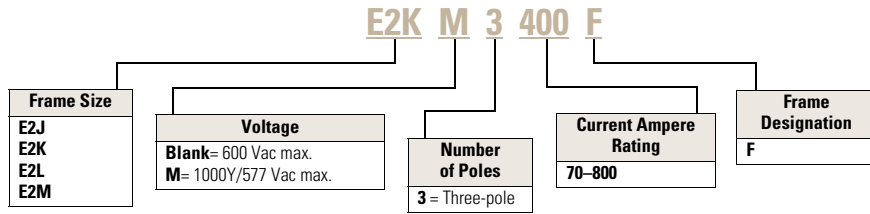

E² Mining Service Breaker with Thermal-Magnetic Trip Unit ①

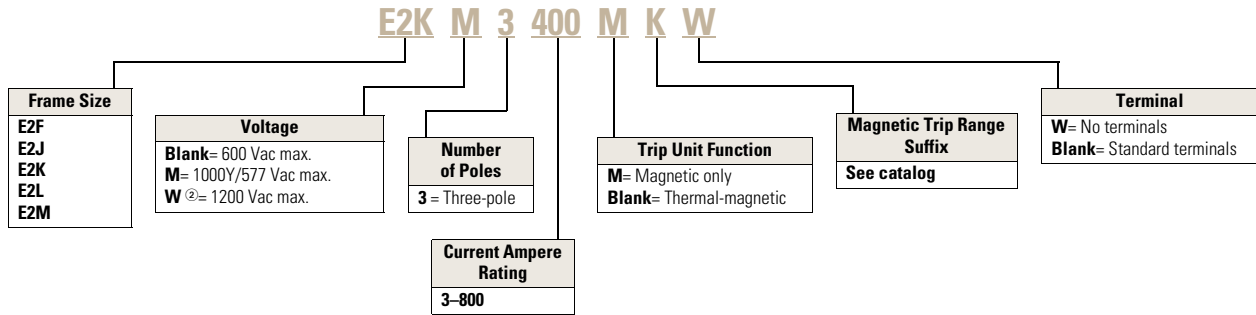

E² Mining Service Thermal-Magnetic Trip Unit ①

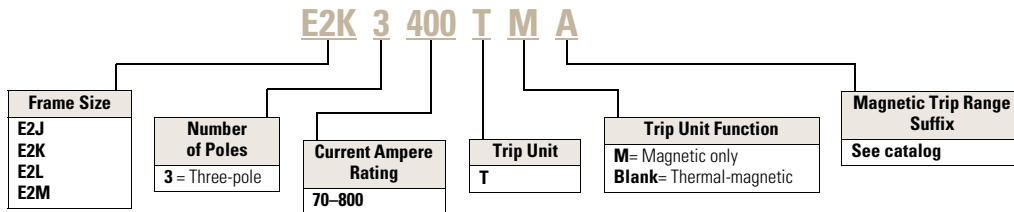

Notes

- ① Does not apply to E2LME/LMZ.
- ② Only available in K-, L- and M-Frames.

Undervoltage Release Mechanism Electrical Rating Data

2

Breaker Type	Supply Voltage	Dropout Voltage		Pickup Voltage Maximum	VA
		Minimum	Maximum		
E ² F/E ² FM	110 Vac	44.5	77	93.5	1.3
	120 Vac				1.5
	127 Vac				1.7
	110 Vdc				1.5
	120 Vdc				1.7
	125 Vdc				1.9
E ² J/E ² JM	110 Vac	44.5	77	93.5	1.8
	120 Vac				2.1
	127 Vac				2.4
	110 Vdc				1.6
	120 Vdc				1.9
	125 Vdc				2.2
E ² K/E ² KM/E ² KW	110 Vac	44.5	77	93.5	1.8
	120 Vac				2.1
	127 Vac				2.4
	110 Vdc				1.6
	120 Vdc				1.9
	125 Vdc				2.2
E ² LME/E ² LMZ	110 Vac	44.5	77	93.5	0.96
	120 Vac				1.13
	127 Vac				1.25
	110 Vdc	43.8	77	93.5	0.94
	120 Vdc				1.12
	125 Vdc				1.21
E ² L/E ² LM/E ² LW/E ² M/ E ² MM/E ² MW	110 Vac	44.5	77	93.5	1.8
	120 Vac				2.1
	127 Vac				2.4
	110 Vdc				1.6
	120 Vdc				1.9
	125 Vdc				2.2
E ² N/E ² NM	110 Vac	44.5	77	93.5	1.8
	120 Vac				2.1
	127 Vac				2.4
	110 Vdc				1.6
	120 Vdc				1.9
	125 Vdc				2.2
E ² R/E ² RM	110 Vac	44.5	77	93.5	3.3
	120 Vac				3.6
	127 Vac				3.8
	110 Vdc	43.8	77	93.5	3.3
	120 Vdc				3.6
	125 Vdc				3.8

Shunt Trip Electrical Rating Data

Breaker Type	Supply Voltage	Operating Voltage		
		Minimum	VA	
E ² F/E ² FM	48 Vac	33.6	92	
	60 Vac		140	
	110 Vac		480	
	120 Vac		570	
	127 Vac		640	
	208 Vac	146	180	
	220 Vac		200	
	230 Vac		240	
	48 Vdc		33.6	100
	60 Vdc			160
	110 Vdc	77		55
	120 Vdc			66
	125 Vdc			71
	E ² J/E ² JM	110 Vac	60.5	66
		120 Vac		84
127 Vac		102		
110 Vdc		77	112	
120 Vdc			138	
E ² K/E ² KM/E ² KW	110 Vac	60	100	
	120 Vac		120	
	127 Vac		140	
	110 Vdc		77	110
	120 Vdc			130
	125 Vdc	140		
	24 Vac	41		
	48 Vac	18		139
	60 Vac		210	
	E ² LME/E ² LMZ	110 Vac	60	83
120 Vac		92		
127 Vac		117		
24 Vdc		120		
48 Vdc		18	475	
60 Vdc			720	
110 Vdc			82	99
120 Vdc		120		
125 Vdc		121		

Breaker Type	Supply Voltage	Operating Voltage		
		Minimum	VA	
E ² L/E ² LM/E ² LW/E ² M/ E ² MM/E ² MW	48 Vac	34	830	
	60 Vac		1280	
	110 Vac		100	
	120 Vac		120	
	127 Vac		140	
	48 Vdc	34	710	
	60 Vdc		1105	
	110 Vdc		77	110
	120 Vdc			130
	125 Vdc			140
E ² N/E ² NM	110 Vac	60	100	
	120 Vac		120	
	127 Vac		140	
	110 Vdc	77	110	
	120 Vdc		130	
E ² R/E ² RM	110 Vac	60.5	330	
	120 Vac		390	
	127 Vac		430	
	110 Vdc	77	370	
	120 Vdc		440	
125 Vdc	480			

Product Selection

3 A–150 A

E²F/E²FM

2

E²F/E²FMSealed Breakers with Non-Interchangeable Trip Unit—Include Line/Load Terminals, Non-Electronic Trip Units ^①

Maximum Continuous Ampere Rating at 40 °C	Magnetic Trip Range	Trip Unit Only Catalog Number	600 Vac Maximum 250 Vdc 35 kA at 480 Vac Three-Pole	1000Y/ 577 Vac Maximum 250 Vdc 10 kA at 1000 Vac Three-Pole
			Complete Breaker Catalog Number	Complete Breaker Catalog Number
Thermal-Magnetic				
15	—	—	E2F3015	—
20	—	—	E2F3020	E2FM3020
25	—	—	E2F3025	E2FM3025
30	—	—	E2F3030	—
35	—	—	E2F3035	—
40	—	—	E2F3040	E2FM3040
45	—	—	E2F3045	—
50	—	—	E2F3050	E2FM3050
60	—	—	E2F3060	E2FM3060
70	—	—	E2F3070	E2FM3070
80	—	—	E2F3080	E2FM3080
90	—	—	E2F3090	E2FM3090
100	—	—	E2F3100	E2FM3100
125	—	—	E2F3125	E2FM3125
150	—	—	E2F3150	E2FM3150
Magnetic Only				
3	9–30	—	E2F003AM	—
7	21–70	—	E2F007CM	—
15	45–150	—	E2F015EM	—
30	90–300	—	E2F030HM	—
	50–150	—	E2F030EM	—
50	150–500	—	E2F050KM	E2FM050KM
	66–190	—	E2F050YM	E2FM050YM
70	210–700	—	E2F070MM	E2FM070MM
100	150–500	—	E2F100KM	E2FM100KM
	300–1000	—	E2F100RM	E2FM100RM
150	450–1500	—	E2F150TM	E2FM150TM
	750–2500	—	E2F150UM	E2FM150UM

Note

^① For two-pole application, use outer poles.

70 A–250 A

E²J/E²JME²J/E²JM

Circuit Breakers with Interchangeable Non-Electronic Trip Units

Maximum Continuous Ampere Rating at 40 °C	Magnetic Trip Range	Trip Unit Only Catalog Number	600 Vac Maximum 250 Vdc 35 kA at 480 Vac Three-Pole ①	1000V/ 577 Vac Maximum 250 Vdc 10 kA at 1000 Vac Three-Pole ②
			Complete Breaker Catalog Number	Complete Breaker Catalog Number
Thermal-Magnetic				
70	300–650	E2J3070T	E2J3070W	E2JM3070W
90	450–900	E2J3090T	E2J3090W	E2JM3090W
100	500–1000	E2J3100T	E2J3100W	E2JM3100W
125	625–1250	E2J3125T	E2J3125W	E2JM3125W
150	750–1500	E2J3150T	E2J3150W	E2JM3150W
175	875–1750	E2J3175T	E2J3175W	E2JM3175W
200	1000–2000	E2J3200T	E2J3200W	E2JM3200W
225	300–650	E2J3225TA	E2J3225AW	E2JM3225AW
	500–1000	E2J3225TD	E2J3225DW	E2JM3225DW
	1125–2250	E2J3225T	E2J3225W	E2JM3225W
250	1250–2500	E2J3250T	E2J3250W	E2JM3250W
Magnetic Only				
250	300–650	E2J3250TMA	E2J3250MAW	E2JM3250MAW
	450–900	E2J3250TMC	E2J3250MCW	E2JM250MCW
	500–1000	E2J3250TMD	E2J3250MDW	E2JM3250MDW
	625–1250	E2J3250TMF	E2J3250MFW	E2JM3250MFW
	750–1500	E2J3250TMG	E2J3250MGW	E2JM3250MGW
	875–1750	E2J3250TMJ	E2J3250MJW	E2JM3250MJW
	1000–2000	E2J3250TMK	E2J3250MKW	E2JM3250MKW
	1125–2250	E2J3250TML	E2J3250MLW	E2JM3250MLW
	1250–2500	E2J3250TM	E2J3250MW	E2JM3250MW

Notes

- ① Frame only: **E2J3250F**.
 ② Frame only: **E2JM3250F**.

100 A–400 A

E²K/E²KM/E²KW

2

E²K/E²KM

Circuit Breakers with Interchangeable Non-Electronic Trip Units

Maximum Continuous Ampere Rating at 40 °C	Magnetic Trip Range	Trip Unit Only Catalog Number	600 Vac Maximum 250 Vdc 35 kA at 480 Vac Three-Pole ^①	1000V/ 577 Vac Maximum 250 Vdc 14 kA at 1000 Vac Three-Pole ^②	1200 Vac Maximum 10 kA at 1200 Vac Three-Pole ^{③④}
Thermal-Magnetic					
100	500–1000	E2K3100T	E2K3100W	E2KM3100W	E2KW3100W
125	625–1250	E2K3125T	E2K3125W	E2KM3125W	E2KW3125W
150	750–1500	E2K3150T	E2K3150W	E2KM3150W	E2KW3150W
175	875–1750	E2K3175T	E2K3175W	E2KM3175W	E2KW3175W
200	1000–2000	E2K3200T	E2K3200W	E2KM3200W	E2KW3200W
225	300–650	E2K3225TA	E2K3225AW	E2KM3225AW	E2KW3225AW
	500–1000	E2K3225TD	E2K3225DW	E2KM3225DW	E2KW3225DW
	1125–2250	E2K3225T	E2K3225W	E2KM3225W	E2KW3225W
250	1250–2500	E2K3250T	E2K3250W	E2KM3250W	E2KW3250W
300	1500–3000	E2K3300T	E2K3300W	E2KM3300W	E2KW3300W
320	1600–3200	—	—	—	E2KW3320W
350	1750–3500	E2K3350T	E2K3350W	E2KM3350W	E2KW3350W
400	2000–4000	E2K3400T	E2K3400W	E2KM3400W	—
Magnetic Only					
400	300–650	E2K3400TMA	E2K3400MAW	E2KM3250MAW	E2KW3250MAW
	500–1000	E2K3400TMD	E2K3400MDW	E2KM3400MDW	E2KW3350MDW
	625–1250	E2K3400TMF	E2K3400MFW	E2KM3400MFW	E2KW3350MFW
	750–1500	E2K3400TMG	E2K3400MGW	E2KM3400MGW	E2KW3350MGW
	875–1750	E2K3400TMJ	E2K3400MJW	E2KM3400MJW	E2KW3350MJW
	1000–2000	E2K3400TMK	E2K3400MKW	E2KM3400MKW	E2KW3350MKW
	1125–2250	E2K3400TML	E2K3400MLW	E2KM3400MLW	E2KW3350MLW
	1250–2500	E2K3400TMW	E2K3400MWW	E2KM3400MWW	E2KW3350MWW
	1500–3000	E2K3400TMN	E2K3400MNW	E2KM3400MNW	E2KW3350MNW
	1600–3200	—	—	—	E2KW3350MVW
	1750–3500	E2K3400TMR	E2K3400MRW	E2KM3400MRW	E2KW3350MRW
	2000–4000	E2K3400TM	E2K3400MW	E2KM3400MW	—

Notes

- ① Frame only: **E2K3400F**.
- ② Frame only: **E2KM3400F**.
- ③ 1200 V breakers are sold as “complete breakers” only.
- ④ Maximum continuous ampere rating at 50 °C.

Please see TD01217001E for detailed dimensions.

100 A–400 A

E²KE/E²KEME²KM

Circuit Breakers with Interchangeable Electronic Trip Units

Maximum Continuous Ampere Rating at 40 °C	Magnetic Trip Range	Trip Unit Only Catalog Number	600 Vac Maximum 250 Vdc 35 kA at 480 Vac Three-Pole ①	1000Y/ 577 Vac Maximum 250 Vdc 14 kA at 1000 Vac Three-Pole ②
			Complete Breaker Catalog Number	Complete Breaker Catalog Number
310+ Electronic Instantaneous Only				
150	50–800	KEM3150TM	E2KE3150MW	E2KEM3150MW
225	200–1500	KEM3225TM	E2KE3225MW	E2KEM3225MW
	500–2500	KEM3225TM2	E2KE3225M2W	E2KEM3225M2W
400	200–1500	KEM3400TM	E2KE3400MW	E2KEM3400MW
	500–2500	KEM3400TM2	E2KE3400M2W	E2KEM3400M2W
310+ Electronic LSI ③				
100	50–800	KEM3100T	E2KE3100W	E2KEM3100W
125	50–800	KEM3125T	E2KE3125W	E2KEM3125W
150	50–800	KEM3150T	E2KE3150W	E2KEM3150W
200	200–1500	KEM3200T	E2KE3200W	E2KEM3200W
225	200–1500	KEM3225T	E2KE3225W	E2KEM3225
	500–2500	KEM3225T2	E2KE32252W	E2KEM32252W
400	200–1500	KEM3400T	E2KE3400W	E2KEM3400W
	500–2500	KEM3400T2	E2KE34002W	E2KEM34002W
310+ Electronic ALSI with Maintenance Mode ③				
100	50–800	KEM310038T	E2KE310038W	E2KEM310038W
125	50–800	KEM312538T	E2KE312538W	E2KEM312538W
150	50–800	KEM315038T	E2KE315038W	E2KEM315038W
200	200–1500	KEM320038T	E2KE320038W	E2KEM320038W
225	200–1500	KEM322538T	E2KE322538W	E2KEM322538
	500–2500	KEM322538T2	E2KE3225238W	E2KEM3225238W
400	200–1500	KEM340038T	E2KE340038W	E2KEM340038W
	500–2500	KEM340038T2	E2KE3400238W	E2KEM3400238W

Notes① Frame only: **E2K3400F**.② Frame only: **E2KM3400F**.③ For High Load Alarm option (B20): **E2KE340038B20W, KEM3400TB20**.

Please see TD01217001E for detailed dimensions.

160 A–400 A

E²LME/E²LMZ (Series G)

2

Circuit Breakers

Maximum Continuous Ampere Rating at 40 °C	Magnetic Trip Range	Trip Unit Only Catalog Number	600 Vac Maximum 250 Vdc 35 kA at 480 Vac Three-Pole ① Complete Breaker Catalog Number	1000V/ 577 Vac Maximum 250 Vdc 14 kA at 1000 Vac Three-Pole ② Complete Breaker Catalog Number
Magnetic Only				
400	3600–4400	LT3400KM	E2LME3400KMW	E2LMZ3400KMW
Interchangeable Electronic Trip Unit				
160	320–1920	LT340031M	E2LME340031W	E2LMZ340031W
200	400–2400	LT340031M	E2LME340031W	E2LMZ340031W
225	450–2700	LT340031M	E2LME340031W	E2LMZ340031W
250	500–3000	LT340031M	E2LME340031W	E2LMZ340031W
300	600–3600	LT340031M	E2LME340031W	E2LMZ340031W
315	630–3780	LT340031M	E2LME340031W	E2LMZ340031W
350	700–4200	LT340031M	E2LME340031W	E2LMZ340031W
400	800–4800	LT340031M	E2LME340031W	E2LMZ340031W

Notes① Frame only: **E2LME3400NN**.② Frame only: **E2LMZ3400NN**.

Please see TD01217001E for detailed dimensions.

300 A–600 A

E²L/E²LM/E²LW

Circuit Breakers with Interchangeable Non-Electronic Trip Units

Maximum Continuous Ampere Rating at 40 °C	Magnetic Trip Range	Trip Unit Only Catalog Number	600 Vac Maximum 250 Vdc 35 kA at 480 Vac Three-Pole ①	1000Y/ 577 Vac Maximum 250 Vdc 18 kA at 1000 Vac Three-Pole ②	1200 Vac Maximum 10 kA at 1200 Vac Three-Pole ③
			Complete Breaker Catalog Number	Complete Breaker Catalog Number	Complete Breaker Catalog Number
Thermal-Magnetic					
300	1500–3000	E2L3300T	E2L3300W	E2LM3300W	E2LW3300W
320	2250–4500	E2L3450T	E2L3450W	E2LM3450W	E2LW3320W
350	1600–3200	—	—	—	E2LW3350W
400	1750–3500	E2L3350T	E2L3350W	E2LM3350W	E2LW3400W
450	2000–4000	E2L3400T	E2L3400W	E2LM3400W	E2LW3450W
500	2500–5000	E2L3500T	E2L3500W	E2LM3500W	—
600	3000–6000	E2L3600T	E2L3600W	E2LM3600W	—
	1125–2250	E2L3600TL ④	—	—	—
Magnetic Only					
450	1600–3200	—	—	—	E2LW3450MVW
	1125–2250	—	—	—	E2LW3450MLW
	1500–3000	—	—	—	E2LW3450MNW
	1750–3500	—	—	—	E2LW3450MRW
	2000–4000	—	—	—	E2LW3450MXW
	2250–4500	—	—	—	E2LW3450MYW
600	1125–2250	E2L3600TML	E2L3600MLW	E2LM3600MLW	—
	1500–3000	E2L3600TMN	E2L3600MNW	E2LM3600MNW	—
	1750–3500	E2L3600TMR	E2L3600MRW	E2LM3600MRW	—
	2000–4000	E2L3600TMX	E2L3600MXW	E2LM3600MXW	—
	2250–4500	E2L3600TMY	E2L3600MYW	E2LM3600MYW	—
	2500–5000	E2L3600TMP	E2L3600MPW	E2LM3600MPW	—
	3000–6000	E2L3600TM	E2L3600MW	E2LM3600MW	—

Notes① Frame only: **E2L3600F**.② Frame only: **E2LM3600F**.

③ Maximum continuous ampere rating at 50 °C.

④ 600 A thermal 1125–2250 T.A.

Please see TD01217001E for detailed dimensions.

300 A–600 A

E²LE/E²LEM

2

E²LM

Circuit Breakers with Interchangeable Electronic Trip Units



Maximum Continuous Ampere Rating at 40 °C	Magnetic Trip Range	Trip Unit Only Catalog Number	600 Vac Maximum 250 Vdc 35 kA at 480 Vac Three-Pole ①	1000Y/ 577 Vac Maximum 250 Vdc 18 kA at 1000 Vac Three-Pole ②
			Complete Breaker Catalog Number	Complete Breaker Catalog Number
310+ Electronic Instantaneous Only				
400	500–2500	LEM3400TM	E2LE3400MW	E2LEM3400MW
	1000–4000	LEM3400TM2	E2LE3400M2W	E2LEM3400M2W
600	500–2500	LEM3600TM	E2LE3600MW	E2LEM3600MW
	2500–5000	LEM3600TM2	E2LE3600M2W	E2LEM3600M2W
310+ Electronic LSI ③				
300	500–2500	LEM3300T	E2LE3300W	E2LEM3300W
350	500–2500	LEM3350T	E2LE3350W	E2LEM3350W
400	500–2500	LEM3400T	E2LE3400W	E2LEM3400W
	1000–4000	LEM3400T2	E2LE34002W	E2LEM34002W
600	500–2500	LEM3600T	E2LE3600W	E2LEM3600W
	2500–5000	LEM3600T2	E2LE36002W	E2LEM36002W
310+ Electronic ALSI with Maintenance Mode ③				
300	500–2500	LEM330038T	E2LE330038W	E2LEM330038W
350	500–2500	LEM335038T	E2LE335038W	E2LEM335038W
400	500–2500	LEM340038T	E2LE340038W	E2LEM340038W
	1000–4000	LEM340038T2	E2LE3400238W	E2LEM3400238W
600	500–2500	LEM360038T	E2LE360038W	E2LEM360038W
	2500–5000	LEM360038T2	E2LE3600238W	E2LEM3600238W

Notes① Frame only: **E2L3600F**.② Frame only: **E2LM3600F**.③ For High Load Alarm option (B20): **E2LE360038B20W, LEM3600TB20**.

Please see TD01217001E for detailed dimensions.

300 A— 800 A

*E²M/E²MM/E²MW**E²M/E²MM/E²MW*

Circuit Breakers with Interchangeable Non-Electronic Trip Units

Maximum Continuous Ampere Rating at 40 °C	Magnetic Trip Range	Trip Unit Only Catalog Number	600 Vac Maximum 250 Vdc 35 kA at 480 Vac Three-Pole ^① Complete Breaker Catalog Number	1000Y/ 577 Vac Maximum 250 Vdc 18 kA at 1000 Vac Three-Pole ^② Complete Breaker Catalog Number	1200 Vac Maximum 12 kA at 1200 Vac Three-Pole ^{③④} Complete Breaker Catalog Number
Thermal-Magnetic					
400	1000–2000	—	—	—	E2MW3400W
500	1250–2500	—	—	—	E2MW3500W
600	1500–3000	E2M3600TN	E2M3600W	E2MM3600W	E2MW3600W
630	1600–3200	—	—	—	E2MW3630W
800	2000–4000	E2M3800TX	E2M3800W	E2MM3800W	E2MW3800W
Magnetic Only					
800	1500–3000	E2M3800TMN	E2M3800MNW	E2MM3800MNW	E2MW3800MNW
	1600–3200	—	—	—	E2MW3800MVW
	2000–4000	E2M3800TMX	E2M3800MXW	E2MM3800MXW	E2MW3800MXW
	2500–5000	E2M3800TMP	E2M3800MPW	E2MM3800MPW	—
	3000–6000	E2M3800TMW	E2M3800MWW	E2MM3800MWW	—

Notes

- ① Frame only: **E2M3800F**.
- ② Frame only: **E2MM3800F**.
- ③ 1200 V breakers are sold as “complete breakers” only.
- ④ Maximum continuous ampere rating at 50 °C.

Please see TD01217001E for detailed dimensions.

800 A

E²ME/E²MEM

2

E²MN**Circuit Breakers with Interchangeable Electronic Trip Units**

Maximum Continuous Ampere Rating at 40 °C	Magnetic Trip Range	Trip Unit Only Catalog Number	600 Vac Maximum 250 Vdc 35 kA at 480 Vac Three-Pole ①	1000Y/ 577 Vac Maximum 250 Vdc 18 kA at 1000 Vac Three-Pole ②
			Complete Breaker Catalog Number	Complete Breaker Catalog Number
310+ Electronic Instantaneous Only				
800	500–2500	MEM3800TM	E2ME3800MW	E2MEM3800MW
	1000–4000	MEM3800TM2	E2ME3800M2W	E2MEM3800M2W
310+ Electronic LSI ③				
800	500–2500	MEM3800T	E2ME3800W	E2MEM3800W
	1000–4000	MEM3800T2	E2ME38002W	E2MEM38002W
310+ Electronic ALSI with Maintenance Mode ③				
800	500–2500	MEM380038T	E2ME380038W	E2MEM380038W
	1000–4000	MEM380038T2	E2ME3800382W	E2MEM3800382W

Notes① Frame only: **E2M3800F**.② Frame only: **E2MM3800F**.③ For High Load Alarm option (B20): **E2ME380038B20W**, **MEM3800TB20**.

Please see TD01217001E for detailed dimensions.

400 A–1200 A

E²N/E²NM**E²NM****Circuit Breakers with Interchangeable Electronic Trip Units**

Maximum Continuous Ampere Rating at 40 °C	Magnetic Trip Range	Trip Unit Only Catalog Number	600 Vac Maximum 250 Vdc 35 kA at 480 Vac Three-Pole	1000Y/ 577 Vac Maximum 250 Vdc 18 kA at 1000 Vac Three-Pole
			Complete Breaker Catalog Number	Complete Breaker Catalog Number
310+ Electronic Instantaneous Only				
800	500–2500	—	E2N3800MW	E2NM3800MW
1200	1250–5000	—	E2N312MW	E2NM312MW
310+ Electronic LSI ^①				
400	500–2500	—	E2N3400W	E2NM3400W
500	500–2500	—	E2N3500W	E2NM3500W
600	500–2500	—	E2N3600W	E2NM3600W
700	500–2500	—	E2N3700W	E2NM3700W
800	500–2500	—	E2N3800W	E2NM3800W
900	1250–5000	—	E2N3900W	E2NM3900W
1000	1250–5000	—	E2N310W	E2NM310W
1200	1250–5000	—	E2N312W	E2NM312W
310+ Electronic ALSI with Maintenance Mode ^①				
400	500–2500	—	E2N340038W	E2NM340038W
500	500–2500	—	E2N350038W	E2NM350038W
600	500–2500	—	E2N360038W	E2NM360038W
700	500–2500	—	E2N370038W	E2NM370038W
800	500–2500	—	E2N380038W	E2NM380038W
900	1250–5000	—	E2N390038W	E2NM390038W
1000	1250–5000	—	E2N31038W	E2NM31038W
1200	1250–5000	—	E2N31238W	E2NM31238W

Notes

^① For High Load Alarm option (B20): **E2N380038B20W**.

Please see TD01217001E for detailed dimensions.

2.5

Molded Case Circuit Breakers

Specialty Breakers

1600 A–2000 A

E²R/E²RM

2

E²RM

Circuit Breakers with Electronic Trip Units



Maximum Continuous Ampere Rating at 40 °C	Magnetic Trip Range	Trip Unit Only Catalog Number	600 Vac Maximum 250 Vdc 35 kA at 480 Vac Three-Pole	1000Y/ 577 Vac Maximum 250 Vdc 18 kA at 1000 Vac Three-Pole
			Complete Breaker Catalog Number	Complete Breaker Catalog Number
310+ Electronic LSI ^①				
1600	2–8 x I _n	—	E2R316W	E2RM316W
2000	2–8 x I _n	—	E2R320W	E2RM320W
310+ Electronic ALSI with Maintenance Mode ^①				
1600	2–8 x I _n	—	E2R31638W	E2RM31638W
2000	2–8 x I _n	—	E2R32038W	E2RM32038W

Notes

^① For High Load Alarm option (B20): **E2R1638B20W**.

Please see TD01217001E for detailed dimensions.

Accessories

Line and Load Terminals

Breaker Type	Maximum Breaker Amperes	Wire Type	AWG Wire Range (No. Conductors)	Catalog Number
E ² F/E ² FM	100	Cu/Al	#14–1/0 (1)	3T100FB (package of three)
	150	Cu	#4–4/0 (1)	3T150FB (package of three)
E ² J/E ² JM	250	Cu	#4–350 (1)	T250KB
E ² K/E ² KM/E ² KW	225	Cu	#3–350 (1)	T300K
	350	Cu	250–500 (1)	T350K
	400	Cu	2/0–250 (2)	3T400K (three-pole kit)
E ² LME/E ² LMZ	400	Cu/Al	500–750 (1)	3TA631LK
E ² L/E ² LM/E ² LW	400	Cu/Al	4/0–600 (1)	3TA401LDK (three-pole kit)
	600	Cu	250–350 (2)	T602LD
E ² M/E ² MM/E ² MW	600	Cu	(2) 2/0–500 kcmil	T600MA1
	600	Cu/Al	(2) 1–500 kcmil	TA700MA1
	800 std.	Cu/Al	(3) 3/0–400 kcmil	TA800MA2
	800	Cu/Al	(2) 500–750 kcmil	TA801MA
	800	Cu	(3) 3/0–300 kcmil	T800MA1
E ² N/E ² NM	700	Cu	2/0–500 (2)	T700NB1
	1000	Cu	3/0–500 (3)	T1000NB1
	1200	Cu	3/0–400 (4)	T1200NB3
	1600	Cu/Al	500–1000 (4)	TA1600RD
	2000	Cu/Al	2–600 (6)	TA2000RD

End Cap Terminals—For Use with Ring Type Terminals

Breaker Type	Maximum Breaker Amperes	Catalog Number	Metric Catalog Number	Imperial
E ² F/E ² FM	150	KPEK1	KPEMK1	—
E ² J/E ² JM	250	KPEK2	KPEMK2	—
E ² K/E ² KM/E ² KW	400	KPEK3	KPEMK3	—
E ² LME/E ² LMZ	400	—	L3RTWK	—
E ² L/E ² LM/E ² LW	600	KPEK4	KPEMK4	—

External Accessories

Padlockable Handle Lock Hasp

Breaker Type	Catalog Number
E ² F/E ² FM	PLK1
E ² J/E ² JM	PLK3
E ² K/E ² KM/E ² KW	PLK3
E ² LME/E ² LMZ	LPHL
E ² L/E ² LM/E ² LW	HLK4
E ² M/E ² MM/E ² MW	HLK4
E ² N/E ² NM	PLK5
E ² R/E ² RM	HLK6

Internal Accessories

2

Undervoltage Release ①

Breaker Type	UVR Type	Voltage Rating	Mounting Location	Catalog Number	Factory Modification Code
E ² F/E ² FM	Handle reset	208–240 Vac	Left pole	UVH1LP11K (thermal/magnetic only) ②	U18
	Handle reset	110–127 Vdc	Left pole	UVH1LP26K (thermal/magnetic only) ②	U42
E ² J/E ² JM	Handle reset	110–127 Vac	Left pole	UVH2LP08K ②	U18
	Handle reset	208–240 Vac	Left pole	UVH2LP11K ②	U22
	Handle reset	110–125 Vdc	Left pole	UVH2LP26K ②	T14
E ² K/E ² KM/E ² KW	120 volt handle reset with LED	120 Vac	Left pole	UVM3LP08K ②③	U66
	120 volt handle reset with LED	120 Vac	Left pole	UVM3LP08KT ②④	U68
	Handle reset	110–127 Vac	Left pole	UVH3LP08K ②	U18
	Handle reset	208–240 Vac	Left pole	UVH3LP11K ②	U22
	Handle reset	110–125 Vdc	Left pole	UVH3LP26K ②	T14
E ² LME/E ² LMZ	Handle reset	110–127 Vac	Left pole	UVR120APK	U5
	Handle reset	110–125 Vdc	Left pole	UVR125DPK	U6
E ² L/E ² LM/E ² LW/E ² M/E ² MM/ E ² MW	120 volt handle reset with LED	120 Vac	Left pole	UVM4LP08K ②③	U66
	120 volt handle reset with LED	120 Vac	Left pole	UVM4LP08KT ②④	U68
	Handle reset	110–127 Vac	Left pole	UVH4LP08K ②	U18
	Handle reset	208–240 Vac	Left pole	UVH4LP11K ②	U22
	Handle reset	110–125 Vdc	Left pole	UVH4LP26K ②	T14
E ² N/E ² NM	120 volt handle reset with LED	120 Vac	Left pole	UVM5LP08K ③	U66
	120 volt handle reset with LED	120 Vac	Left pole	UVM5LT08K ④	U68
	Handle reset	110–127 Vac	Left pole	UVH5LP08K ②	U18
	Handle reset	208–240 Vac	Left pole	UVH5LP11K ②	U22
	Handle reset	110–125 Vdc	Left pole	UVH5LP26K ②	T14
E ² R/E ² RM	120 volt handle reset with LED	120 Vac	Right pole	UVM6RP08K ③⑤	U58
	Handle reset	110–127 Vac	Right pole	UVH6RP08K ⑤	U49
	Handle reset	208–240 Vac	Right pole	UVH6RP11K ⑤	U53
	Handle reset	110–125 Vdc	Right pole	UVH6RP26K ⑤	T33

Notes

- ① Contact Eaton for internal accessory voltage ratings not listed.
- ② LH (RH also available).
- ③ Pigtail leads.
- ④ Terminal blocks.
- ⑤ RH only.

Shunt Trip ①

Breaker Type	Voltage Rating	Mounting Location	Catalog Number	Factory Modification Code
E ² F/E ² FM	48–127 Vac or 48–60 Vdc	Left pole	SNT1LP08K ②	S06
	208–230 Vac or 110–127 Vdc	Left pole	SNT1LP12K ②	S10
E ² J/E ² JM	110–240 Vac or 110–125 Vdc	Left pole	SNT2P11K ③	S10
E ² K/E ² KM/E ² KW	110–240 Vac or 110–125 Vdc	Left pole	SNT3P11K ③	S10
E2LME/E2LMZ	24 Vac/Vdc	Left pole	SNT024CPK	S6
	48–60 Vac/Vdc	Left pole	SNT4860CPK	S7
	110–240 Vac/Vdc	Left pole	SNT120CPK	S2
E ² L/E ² LM/E ² LW/E ² M/ E ² MM/E ² MW	48–60 Vac	Left pole	SNT4LP05K ②	S06
	48–60 Vdc	Left pole	SNT4LP23K ②	S86
	110–240 Vac	Left pole	SNT4LP11K ②	S10
	110–125 Vdc	Left pole	SNT4LP26K ②	S42
E ² N/E ² NM	110–240 Vac	Left pole	SNT5LP11K ②	S10
	110–125 Vdc	Left pole	SNT5LP26K ②	S42
E ² R/E ² RM	110–240 Vac	Right pole	SNT6P11K ④	S29
	110–125 Vdc	Right pole	SNT6P26K ④	S45

Auxiliary Switch

Breaker Type	Number of Sets of Contacts (1A and 1B)	Mounting Location	Catalog Number	Factory Modification Code
E ² F/E ² FM	1	Right	A1X1PK	A06
	2	Right	A2X1RPK	A13
E ² J/E ² JM	1	Right	A1X2PK	A06
	2	Right	A2X2PK	A13
E ² K/E ² KM/E ² KW	1	Right	A1X3PK	A06
	2	Right	A2X3PK	A13
E ² LME/E ² LMZ	1	Right	AUX1A1BPK	A1
	2	Right	AUX2A2BPK	A2
E ² L/E ² LM/E ² LW/E ² M/ E ² MM/E ² MW	1	Right	A1X4PK	A06
	2	Right	A2X4PK	A13
E ² N/E ² NM	1	Right	A1X5PK	A06
	2	Right	A2X5PK	A13
E ² R/E ² RM	2	Right	A2X6RPK	A12
	4	Right	A4X6RPK	A19

Alarm (Signal/Lockout Switch)

Breaker Type	Number of Sets of Contacts (Make and Break)	Mounting Location	Catalog Number	Factory Modification Code
E ² F/E ² FM	1	Right	A1L1LPK/A1L1RPK	B06
	2	Right	A2L1LPK/A2L1RPK	B13
E ² J/E ² JM	1	Right	A1L2LPK/A1L2RPK	B06
E ² K/E ² KM/E ² KW	1	Right	A1L3LPK/A1L3RPK	B06
	2	Right	A2L3LPK/A2L3RPK	B13
E ² LME/E ² LMZ	1	Right	ALM1M1BJPK	B1
	2	Right	ALM2M2BJPK	B3
E ² L/E ² LM/E ² LW/E ² M/ E ² MM/E ² MW	1	Right	A1L4LPK/A1L4RPK	B06
	2	Right	A2L4LPK/A2L4RPK	B13
E ² N/E ² NM	1	Right	A1L5LPK/A1L5RPK	B06
	2	Right	A2L5LPK/A2L5RPK	B13
E ² R/E ² RM	1	Right	A1L6RPK	B05
	2	Right	A2L6RPK	B12

Notes

- ① Contact Eaton for internal accessory voltage ratings not listed.
- ② LH (RH also available).
- ③ LH or RH.
- ④ RH only.

2.5

Molded Case Circuit Breakers

Specialty Breakers

Dimensions

Approximate Dimensions in Inches (mm)

2

Please see TD01217001E for detailed dimensions.

3 A–150 A

E²F/E²FM

Sealed Breakers with Non-Interchangeable Trip Unit—
Include Line/Load Terminals Non-Electronic Trip Units

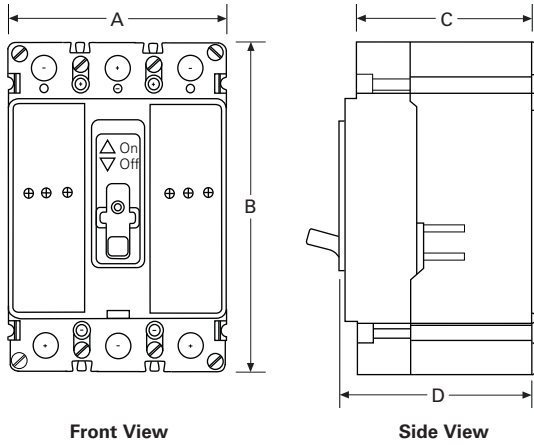

Description	Dimensions in Inches (mm)
A	4.13 (104.9)
B	6.00 (152.4)
C	3.38 (85.9)
D	3.50 (88.9)

70 A–250 A

E²J/E²JM

Circuit Breakers with Interchangeable Non-Electronic
Trip Units

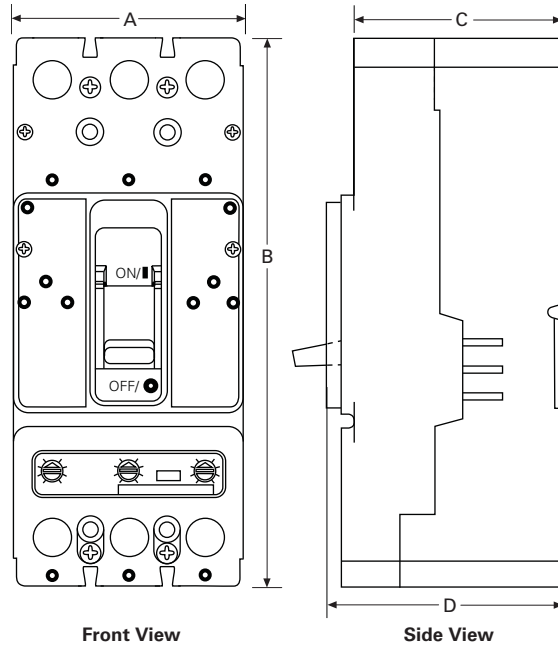

Description	Dimensions in Inches (mm)
A	4.13 (104.9)
B	10.00 (254.0)
C	4.06 (103.1)
D	4.31 (109.5)

Approximate Dimensions in Inches (mm)

Please see TD01217001E for detailed dimensions.

100 A–400 A

E²K/E²KM/E²KW

Circuit Breakers with Interchangeable Non-Electronic Trip Units

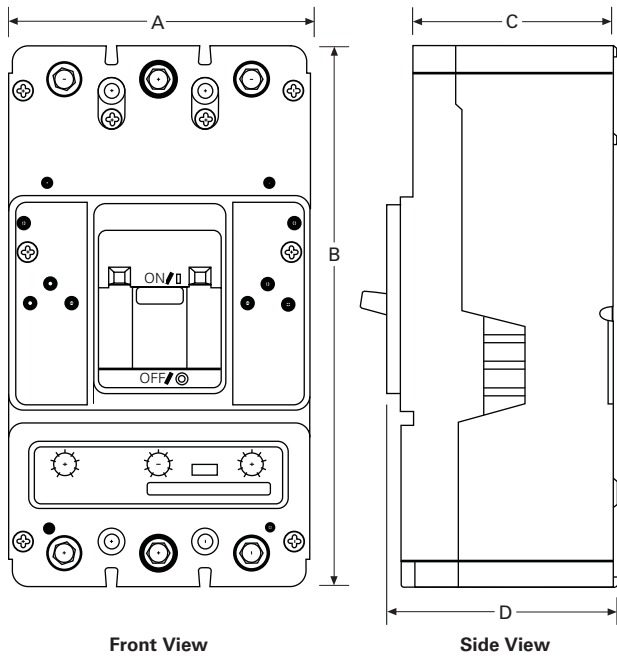

Description	Dimensions in Inches (mm)
A	5.49 (139.4)
B	10.13 (257.3)
C	4.06 (103.1)
D	4.31 (109.5)

100 A–400 A

E²KE/E²KEM

Circuit Breakers with Interchangeable Electronic Trip Units

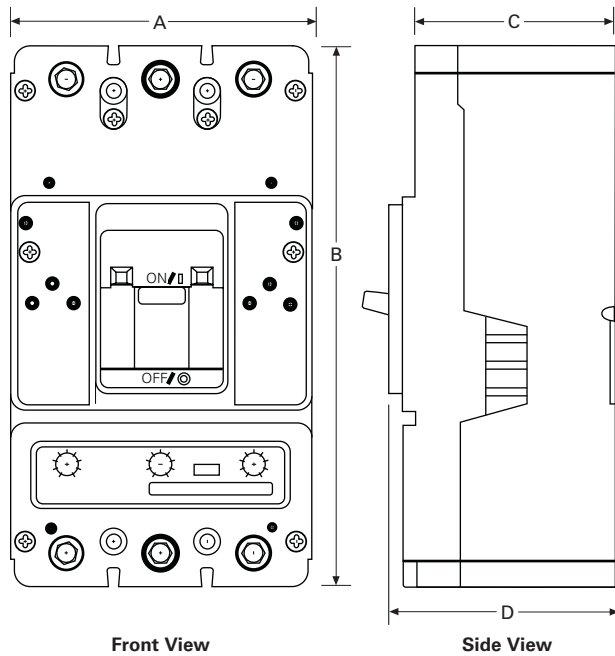

Description	Dimensions in Inches (mm)
A	5.49 (139.4)
B	10.13 (257.3)
C	4.06 (103.1)
D	4.31 (109.5)

2.5

Molded Case Circuit Breakers

Specialty Breakers

Approximate Dimensions in Inches (mm)

Please see TD01217001E for detailed dimensions.

2

160 A–400 A

E²LME/E²LMZ Circuit Breakers

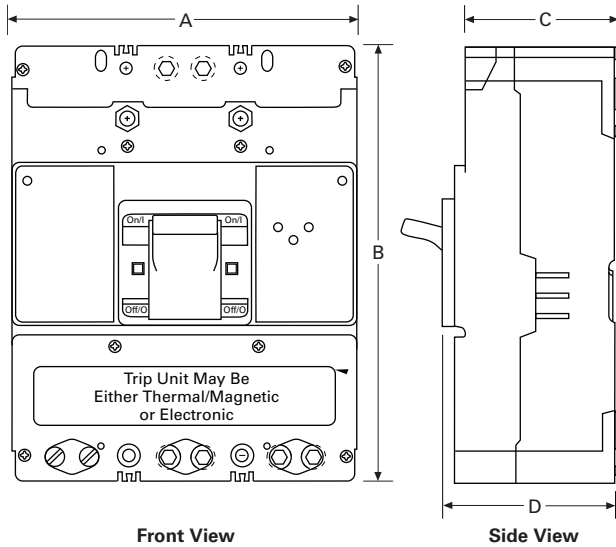

300 A–600 A

E²L/E²LM/E²LW Circuit Breakers with Interchangeable Electronic Trip Units

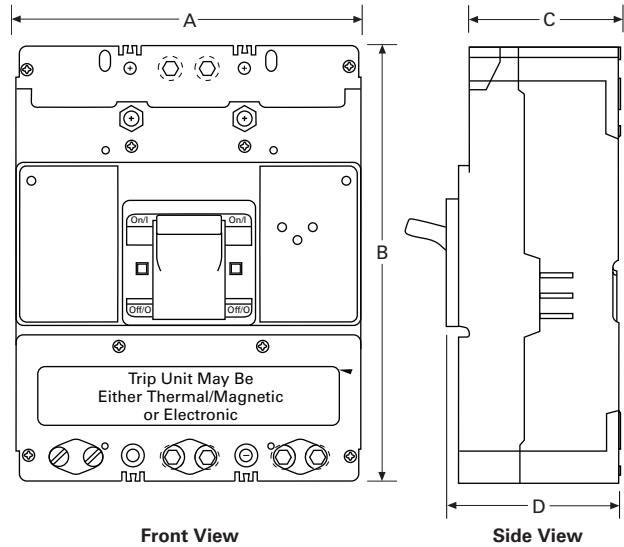

Description	Dimensions in Inches (mm)
A	5.48 (139.2)
B	10.13 (257.3)
C	4.00 (101.6)
D	4.22 (107.1)

Description	Dimensions in Inches (mm)
A	8.25 (209.6)
B	10.75 (273.1)
C	4.06 (103.1)
D	4.38 (111.3)

Approximate Dimensions in Inches (mm)

Please see TD01217001E for detailed dimensions.

300 A–600 A

E²LE/E²LEM

Circuit Breakers with Interchangeable Electronic Trip Units

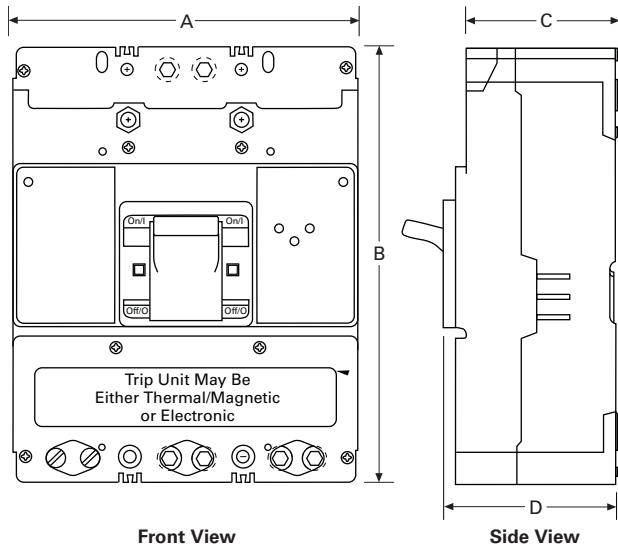

Description	Dimensions in Inches (mm)
A	8.25 (209.6)
B	10.75 (273.1)
C	4.06 (103.1)
D	4.38 (111.3)

300 A–800 A

E²M/E²MM/E²MW

Circuit Breakers with Interchangeable Non-Electronic Trip Units

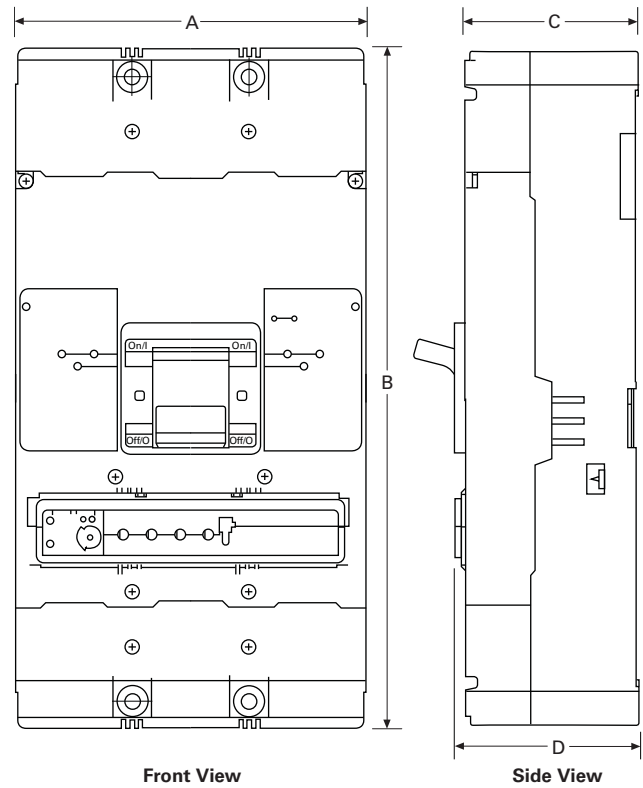

Description	Dimensions in Inches (mm)
A	8.25 (209.6)
B	16.00 (406.4)
C	4.06 (103.1)
D	4.38 (111.3)

2.5

Molded Case Circuit Breakers

Specialty Breakers

Approximate Dimensions in Inches (mm)

Please see TD01217001E for detailed dimensions.

2

800 A

E²ME/E²MEM

Circuit Breakers with Interchangeable Electronic Trip Units

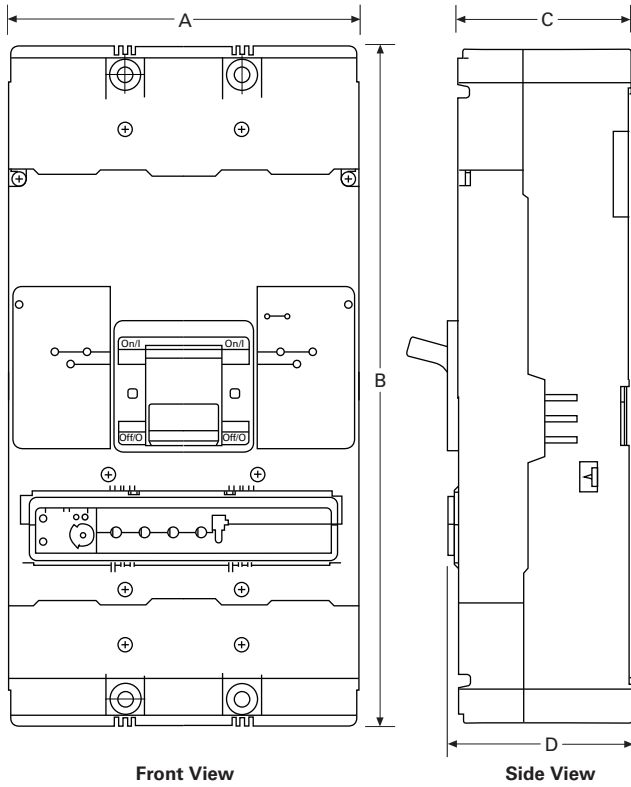

400 A–1200 A

E²N/E²NM

Circuit Breakers with Interchangeable Electronic Trip Units

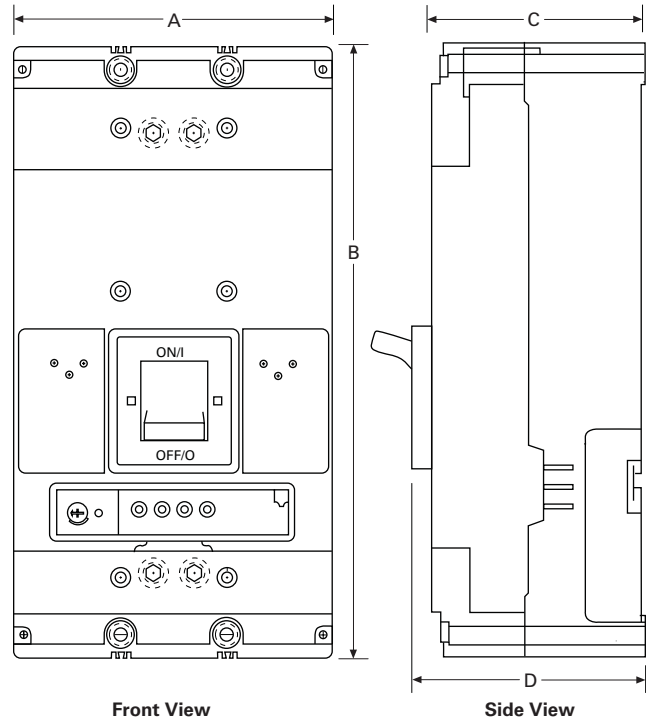

Description	Dimensions in Inches (mm)
A	8.25 (209.6)
B	16.00 (406.4)
C	4.06 (103.1)
D	4.38 (111.3)

Description	Dimensions in Inches (mm)
A	8.25 (209.6)
B	16.00 (406.4)
C	5.50 (139.7)
D	6.00 (152.4)

Approximate Dimensions in Inches (mm)

Please see TD01217001E for detailed dimensions.

1600 A–2000 A

E²R/ E²RM

Circuit Breakers with Electronic Trip Units

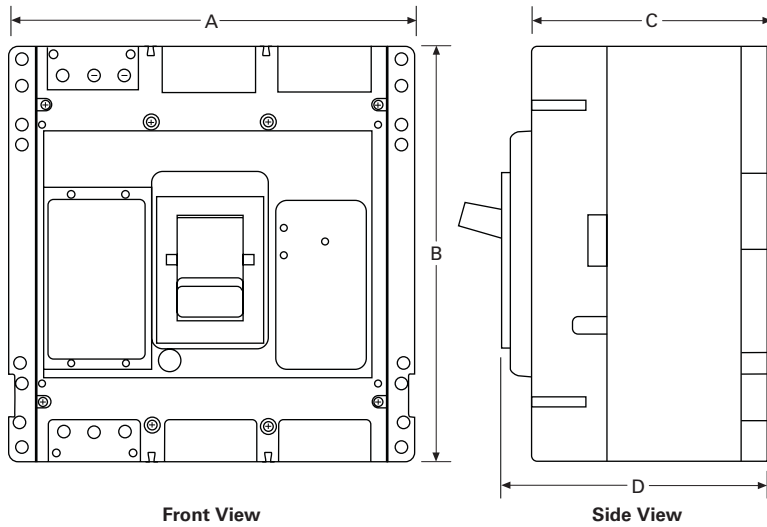

Description	Dimensions in Inches (mm)
A	15.50 (393.7)
B	16.00 (406.4)
C	9.00 (228.6)
D	10.00 (254.0)